

ON THE SET OF WILD POINTS OF ATTRACTING SURFACES IN \mathbb{R}^3

J. J. SÁNCHEZ-GABITES

ABSTRACT. Suppose that a closed surface $S \subseteq \mathbb{R}^3$ is an attractor, not necessarily global, for a discrete dynamical system. Assuming that its set of wild points W is totally disconnected, we prove that (up to an ambient homeomorphism) it has to be contained in a straight line. As a corollary we show that there exist uncountably many different 2-spheres in \mathbb{R}^3 none of which can be realized as an attractor for a homeomorphism.

Our techniques hinge on a quantity $r(K)$ that can be defined for any compact set $K \subseteq \mathbb{R}^3$ and is related to “how wildly” it sits in \mathbb{R}^3 . We establish the topological results that (i) $r(W) \leq r(S)$ and (ii) any totally disconnected set having a finite r must be contained in a straight line (up to an ambient homeomorphism). The main result follows from these and the fact that attractors have a finite r .

INTRODUCTION

Dynamical systems are a rich source of sets with intricate structures. An especially interesting case, because of its dynamical significance, is that of the so-called “strange attractors”. This loose term encompasses both attractors with a complicated topological type and attractors which, in spite of having a rather simple topological type (such as a periodic orbit or an invariant 2-torus), lie in phase space in a complicated way. Their existence prompts the somewhat vague problem of trying to understand how complicated attractors can look. More specifically, one can consider the following *realizability problem*: given a compact set $K \subseteq \mathbb{R}^n$, does there exist a dynamical system on \mathbb{R}^n having K as an attractor? The answer depends on the dimension n of the ambient space, on whether one considers global or local attractors, continuous or discrete dynamics, etc. There are several papers in the literature that deal with this question in some variant or another, among which we may cite [7], [9], [11], [14], [15], [16], [17], [18], [24] or [26].

We may say that the realizability problem is topological in nature in the sense that its answer is a topological invariant of the pair (\mathbb{R}^n, K) . Indeed, if two pairs (\mathbb{R}^n, K) and (\mathbb{R}^n, K') are homeomorphic via a map h , conjugation with h will transform any dynamical system that realizes K as an attractor into another one that does the same for K' (and vice versa), so that either both of K and K' can be realized as attractors or none of them can. Notice that this argument involves the pair (\mathbb{R}^n, K) , rather than K alone. This suggests that the way K sits in \mathbb{R}^n may play a significant role in the realizability problem and invites one to consider the case of *wild sets*, in the sense of geometric topology, which have a simple structure in

2010 *Mathematics Subject Classification.* 54H20, 37B25, 37E99.

Key words and phrases. Attractor, wild surface, discrete dynamical system.

The author is supported by the Spanish Ministerio de Economía y Competitividad (grant MTM 2015-63612-P).

the abstract but are embedded in \mathbb{R}^n in a pathological way. This observation motivated our present study.

Local attractors in two dimensions and attractors *for flows* in three dimensions are well understood: (i) a compact set $K \subseteq \mathbb{R}^2$ can be realized as an attractor if and only if it has finitely generated Čech cohomology; (ii) a compact set $K \subseteq \mathbb{R}^3$ can be realized as an attractor for a flow if and only if $\mathbb{R}^3 - K$ admits a manifold compactification ([24]). Attractors *for homeomorphisms* in three dimensions (and higher) are, however, still fairly mysterious. In this paper we deal with a particular instance of this last case, concentrating on closed surfaces $K = S \subseteq \mathbb{R}^3$. The reason for this is twofold: on the one hand, the most natural two dimensional attractor arising in dynamics is precisely the 2-torus, a closed surface; on the other hand, there is an extensive literature concerning wild surfaces.

Postponing for now the formal details, let us say that a surface $S \subseteq \mathbb{R}^3$ is tame if it can be “smoothed out” within \mathbb{R}^3 . A wild surface is one that is not tame. We shall see later on (Proposition 1) that a tame surface can always be realized as an attractor for a homeomorphism and even for a flow. However, there do exist wild surfaces in \mathbb{R}^3 and the question arises as to whether those can be realized as attractors. The main result of this paper (Theorem 2) is a rather general assertion in this direction: if an attracting surface S has a totally disconnected set W of wild points (points where S cannot be smoothed out within \mathbb{R}^3) then W must be rectifiable; that is, it must be possible to perform an ambient homeomorphism of \mathbb{R}^3 that sends W into a straight line.

Two of the most famous examples of wild surfaces are the 2-spheres due to Antoine and Alexander, and in previous papers we were able to prove that none of them can be realized as an attractor ([25] and [21], jointly with R. Ortega). For the wild sphere of Antoine the set W is a rather peculiar Cantor set called “Antoine’s necklace” which is not rectifiable, so our main result implies directly that this sphere cannot be realized as an attractor. We will generalize Antoine’s construction to show that there are uncountably many different ways to embed any given surface in \mathbb{R}^3 in such a way that it cannot be realized as an attractor (Corollary 3).

Let us say now a few words about the techniques of proof used in the paper, which may be of independent interest. Our main tool will be certain number $r(K) = 0, 1, \dots, \infty$ that can be associated to any compact set $K \subseteq \mathbb{R}^3$ and somehow measures its “crookedness” as a subset of Euclidean space. This number is a purely topological quantity, but it has the property of being finite when K is an attractor and therefore establishes the link between topology and dynamics. The hard work will be in proving, again as purely topological results, that: (i) for a surface S having a totally disconnected set W of wild points the inequality $r(S) \geq r(W)$ holds; and (ii) for a totally disconnected compact set T one has $r(T) < \infty$ if and only if T is rectifiable. The main theorem then follows as an application: since S is an attractor $r(S) < \infty$, then by (i) one has $r(W) < \infty$ too, and finally (ii) implies that W is rectifiable.

We would like to conclude this Introduction by expressing our warmest thanks to the anonymous referee of the paper for his or her thorough reading, corrections and suggestions.

1. STATEMENT OF RESULTS

Let f be a homeomorphism of \mathbb{R}^3 . By an *attractor* K for f we mean a compact invariant set (that is, $f(K) = K$) which attracts all compact subsets of some neighbourhood U of K . This means that for every compact set $P \subseteq U$ and every neighbourhood V of K in \mathbb{R}^3 there exists $n_0 \in \mathbb{N}$ such that $f^n(P) \subseteq V$ for every $n \geq n_0$. In the language of dynamics, K is stable in the sense of Lyapunov and attracts all points in U . Notice that no particular assumption is made about the size of U , so K is a local but not necessarily global attractor.

By a *closed surface* we mean a compact 2-manifold without boundary. A closed surface $S \subseteq \mathbb{R}^3$ is *locally flat* at a point p if p has a neighbourhood U in \mathbb{R}^3 such that the pair $(U, U \cap S)$ is homeomorphic to $(\mathbb{R}^3, \mathbb{R}^2 \times \{0\})$. This definition is standard; see for instance the book by Daverman and Venema [8, p. xvi]. Intuitively it means that, near p , the surface lies in \mathbb{R}^3 like a plane. For instance, every piecewise linear surface $S \subseteq \mathbb{R}^3$ is locally flat at every point, and the same holds true when S is a differentiable submanifold of \mathbb{R}^3 because of the existence of adapted charts.

Our first result is very simple:

Proposition 1. *Let $S \subseteq \mathbb{R}^3$ be a closed surface that is locally flat at every point. Then S is an attractor for a homeomorphism (and actually, also for a flow) of \mathbb{R}^3 .*

The only purpose of the above proposition is to show that, since we are interested in finding surfaces that cannot be attractors, we need to turn our attention to surfaces that contain points at which the surface is not locally flat. These points, and the surface itself, we call *wild*, although this is a slight abuse of terminology¹. The set of wild points is clearly closed so, when nonempty, it is compact. It might be difficult at first to imagine how a surface could fail to be locally flat, but we shall see an example after stating our main theorem below.

We need a final definition: let us say that a totally disconnected compact set $T \subseteq \mathbb{R}^3$ is *rectifiable* if there exists a homeomorphism of \mathbb{R}^3 that sends T into a straight line. Again, it might be difficult to imagine how a totally disconnected compact set $T \subseteq \mathbb{R}^3$ may not be rectifiable. Rather than presenting an example now, we postpone this to Section 4 where we recall the definition of “Antoine’s necklace”, which is a Cantor set that is not rectifiable. As the reader will see, the construction is very flexible and can be modified to produce a great variety of Cantor sets that are not rectifiable.

The main result of the paper is the following:

Theorem 2. *Let $S \subseteq \mathbb{R}^3$ be a closed, connected surface that bounds a 3-manifold. Suppose that S contains a compact, totally disconnected set T such that:*

- (i) *S is locally flat at each $p \notin T$.*
- (ii) *T is not rectifiable.*

Then S cannot be realized as an attractor for a homeomorphism of \mathbb{R}^3 .

Theorem 2 is stated in the form most convenient for the construction of nonattracting surfaces that follows below. However, it can also be presented (as we did in the abstract and

¹Formally, a wild point is one where the surface is not locally *tame* rather than not locally flat. However, in the case that concerns us now, both notions are equivalent. More on this in Section 2.

the Introduction) as an assertion about the set of wild points of an attracting surface, as follows:

Theorem 2'. *Let $S \subseteq \mathbb{R}^3$ be a closed surface that bounds a 3-manifold and is an attractor for a homeomorphism. Suppose that its set of wild points W is totally disconnected. Then W must be rectifiable.*

The condition that S bounds a 3-manifold means the following. Recall that any closed, connected surface S separates \mathbb{R}^3 into two connected components U_i whose closures are $\bar{U}_i = U_i \cup S$. This follows from Alexander duality and the fact that S is a surface (see for instance the argument in [20, Theorem 36.3, p. 205]). We say that S *bounds a 3-manifold* if at least one of the \bar{U}_i is a 3-manifold (possibly noncompact) with boundary. The definition for a non connected S is similar. Although this condition is fulfilled in many of the classical examples of wild surfaces, it is added for technical reasons and it would be nice if it could be removed from the theorem.

Constructing nonattracting surfaces. We now explain how to construct examples of surfaces that cannot be attractors. The procedure we describe is essentially the same as the one used by Antoine to construct a wild sphere. Let $T \subseteq \mathbb{R}^3$ be a totally disconnected, compact set of \mathbb{R}^3 . Eventually we shall take T to be non rectifiable, but this is not necessary for the moment. As with any compact subset of \mathbb{R}^3 , we can find a sequence $(N_k)_{k=1}^\infty$ of compact 3-manifolds with boundary such that N_{k+1} is contained in the interior of N_k for each k and T is the intersection of the N_k . Since T is totally disconnected, in addition we may require that (i) the diameters of the connected components of the N_k converge to zero as $k \rightarrow \infty$ and (ii) every connected component of each N_k meets T , since those that do not can be removed. Figure 1 shows a totally disconnected set T (suggested by the cloud of dots, presumably infinite) and the two first neighbourhoods of a possible sequence (N_k) . The first one is a single cell. The second one N_2 already consists of three connected components $N_{2,1}$, $N_{2,2}$, $N_{2,3}$ (a cell, a solid torus, and a solid double torus).

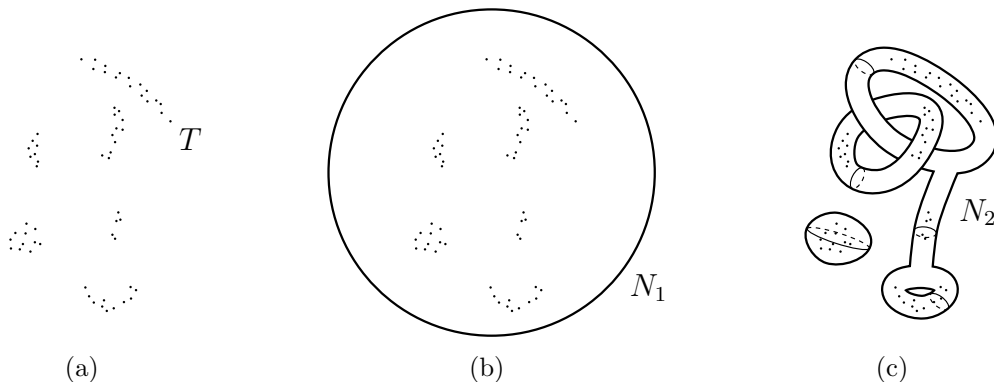

FIGURE 1. A totally disconnected set T and a couple of its neighbourhoods N_k

Let $S_0 \subseteq \mathbb{R}^3$ be a closed, locally flat surface such that T lies in its exterior. For simplicity we shall take S_0 to be the boundary of a closed, round ball B_0 disjoint from T . We are

going to modify B_0 , without changing its topological type, so that the resulting 3-manifold B contains T in its boundary. In order to do this we take the N_k as a guide. First, we extract a solid “feeler” from B_0 that connects it to the boundary of N_1 , meeting it in a disk D_1 . See Figure 2.(a), where B_0 and the feeler are shown in a thicker outline and D_1 is shaded gray. Then, within N_1 , we branch the feeler into “subfeelers”, each one connected to a different component $N_{2,j}$ of N_2 . Again, these subfeelers should meet the boundary of their corresponding $N_{2,j}$ in a disk $D_{2,j}$. See Figure 2.(b). Although Figure 2 does not show this for simplicity, the feelers may be knotted or entangled.

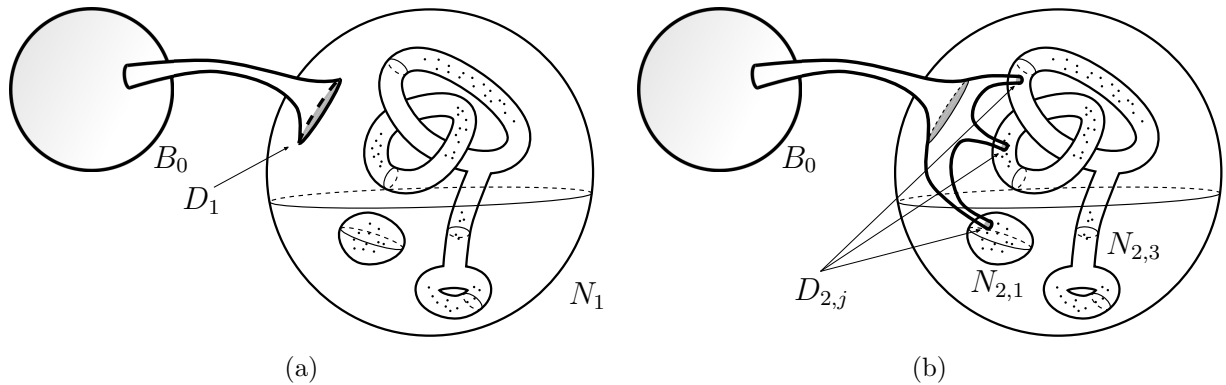

FIGURE 2. Modifying B_0 so that its boundary contains T

We work in the same fashion within each component $N_{2,j}$ of N_2 , splitting the subfeelers into even thinner subfeelers connected to those components of N_3 contained in $N_{2,j}$; then at an even smaller scale within the components $N_{3,j}$ of N_3 , and so on. This gives rise to a nested sequence of compact 3-manifolds, each larger but homeomorphic to the previous one. Let B be the union of this sequence and the set T , which is the limit set of the feelers. It is not difficult to check that B is a compact 3-manifold homeomorphic to B_0 (see for instance the arguments in [8, Chapter 2, pp. 46 ff.]). It may be convenient to mention that B may well not be *ambient* homeomorphic to B_0 ; that is, there may not exist a homeomorphism of all of \mathbb{R}^3 that sends B onto B_0 .

Let the surface S be the boundary of B . Then S is homeomorphic to the original S_0 and bounds a 3-manifold (the manifold B itself). Also, by construction it contains T and, if the feelers are drawn in a locally flat fashion as in Figure 2, clearly S is locally flat at each point except for, possibly, at those belonging to T . Therefore, choosing T to be non rectifiable (for instance, letting T be Antoine’s necklace, which is described in Section 4), Theorem 2 guarantees that S cannot be realized as an attractor.

We will show in Section 6 how to refine the above construction to prove that every closed (orientable) surface can be embedded in \mathbb{R}^3 in uncountably many different ways $\{S_i : i \in I\}$ none of which can be realized as an attractor. By “different” we mean that for any two different $i \neq j$ there does not exist a homeomorphism of \mathbb{R}^3 that sends S_i onto S_j . This is true even if one considers only the simplest possible surface, a 2-sphere:

Corollary 3. *There exist uncountably many different 2–spheres in \mathbb{R}^3 that cannot be realized as attractors.*

We finish this section with some remarks about Theorem 2:

Remark 4. (1) The construction just described illustrates why Theorem 2 is more convenient than Theorem 2' to establish the nonattracting nature of a given surface. To apply Theorem 2 we only needed to check that the surface in question was locally flat outside T , and that was straightforward. Had we tried to apply Theorem 2', we would have needed to identify the set W of wild points precisely, which is not easy to do (in fact, W depends on the particular details of how the construction is performed).

(2) The conditions laid out in Theorem 2 are sufficient, but not necessary, to guarantee that a surface (even a surface with a totally disconnected set of wild points) cannot be an attractor. A suitable example is the horned sphere S of Alexander, which cannot be realized as an attractor (this is proved in [25, Theorem 41, p. 3620]) but whose set of wild points is a rectifiable Cantor set because it is contained in a straight line by construction. The Alexander sphere is shown in Figure 3 and described carefully in [8, Chapter 2]. One may think of S as the round sphere \mathbb{S}^2 from which infinitely many feelers have been extracted which, as their diameters tend to zero, converge to the Cantor set of wild points at the bottom of the figure. In contrast to the construction “à la Antoine” described earlier, where the feelers could or could not be entangled, here they must be entangled, for this is what ultimately lends the sphere its wild nature.

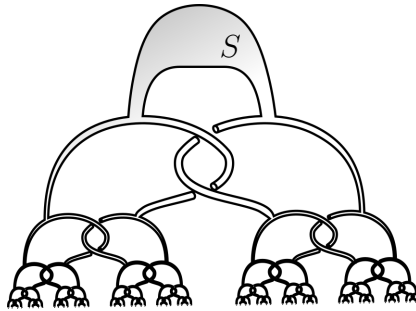

FIGURE 3. The sphere of Alexander

This example begs the question of whether it is possible to generalize Theorem 2 so that it covers both the examples of Antoine and Alexander. Heuristically, such a generalization would somehow capture simultaneously the “contributions to the wildness” of S due to both the non rectifiability of W itself and the entanglement of the surface as it approaches W .

The rest of the paper is organized as follows. Proposition 1 is proved in the very brief Section 2, where we also discuss succinctly the relation between wildness and tameness. In Section 3 we recall from [25] the definition and properties of the quantity $r(K)$ mentioned earlier as being our main tool. The following two sections are devoted to two purely topological results. Section 4 is devoted to the study of $r(T)$ for totally disconnected compact sets T . The main theorem there is Theorem 14, which shows that $r(T)$ is either zero or infinity depending on

whether T is rectifiable or not, respectively. In Section 5 we essentially prove the inequality $r(B) \geq r(W)$, where $B \subseteq \mathbb{R}^3$ is a compact 3-manifold and W is the set of wild points of its boundary ∂B . This result was essentially stated as (i) at the end of the Introduction, albeit in a slightly stronger form that is more convenient (see however Theorem 17'). The main theorem is finally established in Section 6 together with Corollary 3. A final section contains several open questions that seem interesting for further investigations.

2. PROOF OF PROPOSITION 1

In Section 1 we defined a wild surface S as one having at least one wild point; that is, a point at which the surface is not locally flat. Formally, wildness is not related to local flatness but to local tameness, so we shall devote a few lines to clarify the relation between these concepts.

Let us begin by defining a *polyhedron* P as the geometric realization of a finite simplicial complex in \mathbb{R}^3 (although very restrictive, this definition is enough for our purposes). A compact set $K \subseteq \mathbb{R}^3$ is *tame* if there exists an ambient homeomorphism $h : \mathbb{R}^3 \rightarrow \mathbb{R}^3$ such that $h(K)$ is a polyhedron. And it is *locally tame* at a point $p \in K$ if there exist a (closed) neighbourhood V of p in \mathbb{R}^3 and an embedding $e : V \rightarrow \mathbb{R}^3$ such that $e(V \cap K)$ is a polyhedron. These two definitions are classical; see for instance [19, p. 145]. Evidently a tame set is locally tame at each point. A deep theorem of Bing, proved independently by Moise, states that the converse is also true: a locally tame subset of \mathbb{R}^3 is tame [19, Theorem 4, p. 254].

The above definitions are set up for any compact subset of \mathbb{R}^3 , but we are interested in the case of closed surfaces S . The following holds true for them:

Remark 5. For a closed surface $S \subseteq \mathbb{R}^3$, being locally flat at a point p is equivalent to being locally tame at that same point p .

Proof. In this paper we shall only make use of implication (\Rightarrow), whose simple proof we give in detail. The converse, although conceptually easy, is rather technical and we only give an intuitive idea.

(\Rightarrow) By local flatness there exist a neighbourhood U of p in \mathbb{R}^3 and a homeomorphism h between $(U, U \cap S)$ and $(\mathbb{R}^3, \mathbb{R}^2 \times \{0\})$. Without loss of generality we can assume that $h(p)$ is the origin. Let $W := [-1, 1] \times [-1, 1] \times [-1, 1]$. Clearly $V := h^{-1}(W)$ is a neighbourhood of p in \mathbb{R}^3 , and the restriction $e := h|_V$ is an embedding such that $e(V \cap S) = W \cap (\mathbb{R}^2 \times \{0\})$, which is a square (hence a polyhedron). Therefore S is locally tame at p .

(\Leftarrow) Since S is locally tame at p , we may think of it (via the embedding e of the definition of local tameness) as a polyhedral surface around p . Thus p has a neighbourhood in S that is a polyhedral disk. Such a disk can be flattened out. Therefore S is locally flat around p . \square

Thus for a surface S one may equivalently define a point $p \in S$ to be wild whenever S is not locally flat or not locally tame at p . The former characterization is self contained (it makes no reference to polyhedra), which is why we used it in the previous section. It is also the most convenient definition for later sections. In this section, however, the characterization in terms of polyhedra is more useful.

We want to prove Proposition 1, which claims that a closed surface that is locally flat at every point can be realized as an attractor for a homeomorphism or, in fact, for a flow. In order to show this we need a simple auxiliary result whose proof we omit:

Lemma 6. *Let $P \subseteq \mathbb{R}^3$ be a polyhedron. Then there exists a flow in \mathbb{R}^3 having P as an attractor.*

Proof. See [15, Corollary 4, p. 327] or [24, Proposition 12, p. 6169]. \square

Proof of Proposition 1. Suppose that S has no wild points, so that by definition it is locally flat at each $p \in S$. By Remark 5 this implies that S is locally tame at each $p \in S$ and by the theorem of Bing and Moise mentioned earlier, S is tame. Thus, there exists a homeomorphism $h : \mathbb{R}^3 \rightarrow \mathbb{R}^3$ such that $h(S)$ is a polyhedron. In turn, by Lemma 6 there exists a flow having $h(S)$ as an attractor. Let f be the time-one map of this flow, so that $h(S)$ is an attractor for the homeomorphism f of \mathbb{R}^3 . Then S is an attractor for $h^{-1}fh$. \square

3. THE NUMBER $r(K)$

In [25] we described how to associate, to each compact subset $K \subseteq \mathbb{R}^3$, a number $r(K)$ that provides a measure of how wildly K sits in \mathbb{R}^3 . We used it to show that certain arcs, balls and spheres (for instance, the horned sphere of Alexander in Figure 3.(b)) cannot be attractors. Since this number $r(K)$ will also be the fundamental tool in the proof of Theorem 2, we devote this section to review its definition and some of its properties. We refer the reader to [25] for more details and proofs.

Let $K \subseteq \mathbb{R}^3$ be an arbitrary compact subset of \mathbb{R}^3 . It is easy to see that any neighbourhood of K contains a smaller one N which is a compact, polyhedral 3-manifold. For instance, cover K with the interiors of closed cubes contained in U ; discard all of them but finitely many using the compactness of K , thus obtaining a polyhedral P neighbourhood of K , and finally let N be a regular neighbourhood of P (in the sense of piecewise linear topology [22, Chapter 3, pp. 31 ff. and particularly Proposition 3.10, p. 34]). We call such an N a pm -neighbourhood of K (pm standing for polyhedral manifold). For r a nonnegative integer, consider the following property that K may or may not have:

(P_r) : K has arbitrarily small pm -neighbourhoods N with $\text{rk } H_1(N) \leq r$.

Here $H_1(N)$ denotes the first homology group of N with \mathbb{Z}_2 coefficients and rk denotes its rank as an Abelian group or, equivalently, its dimension as a vector space over \mathbb{Z}_2 .

Definition 7. $r(K)$ is the smallest nonnegative integer r for which (P_r) holds, or ∞ if (P_r) does not hold for any r .

Although the definition of $r(K)$ does not make any reference to dynamics, it has the following property which justifies our interest in it:

(P1) *Finiteness.* If K is a local attractor for a homeomorphism then $r(K) < \infty$.

Proof. See [25, Theorem 13, p. 3599]. \square

Essentially, the proof of Theorem 2 will consist in showing that $r(S) = \infty$ and applying the finiteness property. However, computing $r(K)$ from first principles is in general very difficult and we will need to do it indirectly, making use of several additional properties of $r(K)$ that

are, this time, geometric in nature: invariance, semicontinuity, nullity and subadditivity. We state them now.

(P2) *Invariance.* If K and K' are ambient homeomorphic, then $r(K) = r(K')$.

Proof. See [25, Theorem 14, p. 3600]. \square

(P3) *Semicontinuity.* Suppose $(K_n)_{n \geq 1}$ is a decreasing sequence (that is, $K_{n+1} \subseteq K_n$ for every n) of compact sets and denote by K its intersection. Then

$$r(K) \leq \liminf_{n \rightarrow \infty} r(K_n).$$

Proof. Define $r := \liminf_{n \rightarrow \infty} r(K_n)$. If $r = \infty$ there is nothing to prove, so assume that $r < \infty$. Passing to a subsequence of the K_n we may assume that $r(K_n) = r$ for every $n \in \mathbb{N}$, so that each K_n has property (P_r) . Let U be a neighbourhood of K . The K_n form a decreasing sequence and $K = \bigcap K_n$, so there exists n_0 such that $K_n \subseteq U$ for every $n \geq n_0$. Since K_{n_0} has property (P_r) , it has a pm -neighbourhood $N \subseteq U$ such that $\text{rk } H_1(N) \leq r$. But N is also a neighbourhood of K , so K has property (P_r) too. \square

(P4) *Nullity.* Suppose K has $\check{H}^2(K) = 0$. Then $r(K) = 0$ if, and only if, K has arbitrarily small pm -neighbourhoods N such that each component of N is a 3-cell. By a 3-cell we mean a set homeomorphic to the closed unit 3-ball $\mathbb{B}^3 \subseteq \mathbb{R}^3$.

Proof. This is proved in [25, Theorem 16, p. 3601] for K connected (in that case N can be taken to be connected too and it is itself a 3-cell). The same argument given there covers this slightly more general situation where K is not assumed to be connected. \square

Finally, to state the subadditivity property we need to introduce some notation and a definition:

Notation 8. Consider the following subsets of \mathbb{R}^3 , shown in Figure 4:

- Q_0 is the parallelepiped $[-1, 0] \times [-1, 1] \times [-1, 1]$,
- Q_1 is the parallelepiped $[0, 1] \times [-1, 1] \times [-1, 1]$,
- Q is the cube $Q_0 \cup Q_1$,
- S is the square $Q_0 \cap Q_1 = \{0\} \times [-1, 1] \times [-1, 1]$,
- \dot{S} denotes the square S minus its edges.

Suppose K is expressed as the union of two compact sets K_0 and K_1 . We call this a *decomposition* of K and introduce the following definition:

Definition 9. A decomposition $K = K_0 \cup K_1$ is *tame* if

- (i) $K \cap S = K_0 \cap K_1 \subseteq \dot{S}$,
- (ii) $K_0 \cap Q \subseteq Q_0$ and $K_1 \cap Q \subseteq Q_1$.

Definition 9 conveys the intuitive idea that S realizes *geometrically* the purely set-theoretical decomposition $K = K_0 \cup K_1$. The part of K that lies in Q is structured in two ‘halves’, $K \cap Q_0$ and $K \cap Q_1$. The first one sits in Q_0 and, because of condition (ii), is comprised exclusively of points from K_0 . The second one sits in Q_1 and is comprised exclusively of points from K_1 .

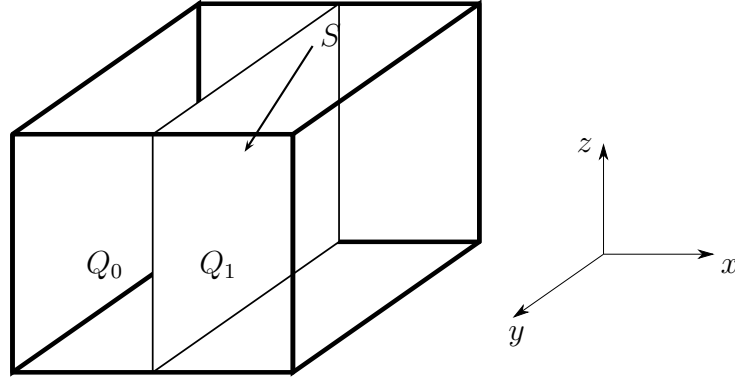

FIGURE 4. The setup for Definition 9

Remark 10. It is convenient to widen Definition 9 slightly and say that a decomposition $K = K_0 \cup K_1$ is tame if there exists an ambient homeomorphism $h : \mathbb{R}^3 \rightarrow \mathbb{R}^3$ that takes K , K_0 and K_1 onto sets that satisfy (i) and (ii) above. This convenient generalization has no consequences as far as $r(K)$ is concerned since r is invariant under ambient homeomorphisms by (P2).

A prototypical example of a tame decomposition (in the wider sense just mentioned) of a set K would be as follows:

Example 11. Take a plane $H \subseteq \mathbb{R}^3$ (having a nonempty intersection with K) and, denoting H_0 and H_1 the two closed halfspaces determined by H , let $K_0 := K \cap H_0$ and $K_1 := K \cap H_1$. Then $K = K_0 \cup K_1$ is a tame decomposition.

Now we can state the subadditivity property of r :

(P5) *Subadditivity.* Let $K = K_0 \cup K_1$ be a tame decomposition of K and assume that $\check{H}^1(K_0 \cap K_1) = 0$. Then the inequality $r(K) \geq r(K_0) + r(K_1)$ holds.

Proof. See [25, Theorem 22, p. 3604]. □

If one thinks of r as some sort of Betti number and writes the Mayer-Vietoris sequence for $K = K_0 \cup K_1$, the necessity of requiring that $\check{H}^1(K_0 \cap K_1)$ be zero is clear. The role of the tameness condition is more delicate. Roughly, it guarantees that certain geometrical constructions leading to the inequality $r(K) \geq r(K_0) + r(K_1)$ can be performed. Without this assumption the subadditivity property may be false (see [25, Example 25, p. 3606]).

For our purposes in this paper it is convenient to have a more flexible way of checking whether a decomposition is tame. The following proposition provides this:

Proposition 12. Let $K = K_0 \cup K_1$ be a decomposition of a compact set $K \subseteq \mathbb{R}^3$. Suppose that there exists an embedding $e : Q \rightarrow \mathbb{R}^3$ such that:

- (1) $K \cap e(S) = K_0 \cap K_1 \subseteq e(\dot{S})$,
- (2) $K_0 \cap e(Q) \subseteq e(Q_0)$ and $K_1 \cap e(Q) \subseteq e(Q_1)$.

Then the decomposition is tame.

In the proof we will make use of the (generalized) Schönflies Theorem, so we devote a few lines to explain it. A 2-sphere $\Sigma \subseteq \mathbb{R}^2$ is simply an embedded copy of the unit two dimensional sphere $\mathbb{S}^2 \subseteq \mathbb{R}^3$. The Schönflies Conjecture states that any two 2-spheres Σ_1 and Σ_2 in \mathbb{R}^3 are equivalently embedded; that is, there exists an ambient homeomorphism that sends one of them onto the other. As stated, this result is false due to the existence of wild spheres, so some additional hypothesis needs to be added. Brown gave a beautiful version for bicollared spheres. A 2-sphere $\Sigma \subseteq \mathbb{R}^3$ is *bicollared* if there exists an embedding $b : \Sigma \times [-1, 1] \rightarrow \mathbb{R}^3$ such that $b(p, 0) = p$ for every $p \in \Sigma$. Brown proved [4, Theorem 5, p. 76] that the Schönflies Conjecture is true for bicollared spheres; that is, if $\Sigma_1, \Sigma_2 \subseteq \mathbb{R}^3$ are two bicollared spheres, there exists an ambient homeomorphism that sends one of them onto the other. We shall refer to this result as the generalized Schönflies Theorem.

Now let $B_1, B_2 \subseteq \mathbb{R}^3$ be two 3-cells and $e : B_1 \rightarrow B_2$ a homeomorphism. Assume that both ∂B_1 and ∂B_2 are bicollared. Then e admits an extension to a homeomorphism \hat{e} of all \mathbb{R}^3 . The reason is that the generalized Schönflies Theorem applies to the bicollared 2-spheres ∂B_1 and ∂B_2 and allows one to reduce this problem to the case where $B_1 = B_2 = \mathbb{B}^3$, where \mathbb{B}^3 denotes the closed unit ball in Euclidean space \mathbb{R}^3 , and then extending e is a simple matter (do it radially).

Proof. We need to construct a homeomorphism h of \mathbb{R}^3 that sends K_0 and K_1 onto sets satisfying the conditions in Definition 9. Let B_1 and B_2 be the 3-cells Q and $e(Q)$, respectively, and consider the 2-spheres ∂B_1 and ∂B_2 . Clearly ∂B_1 is bicollared, since B_1 is a polyhedral cube. As for ∂B_2 , the following claim shows that we can assume it to be bicollared too:

Claim. Maybe after a suitable improvement of e , we may assume that the boundary of $e(Q)$ is bicollared.

Proof of claim. For any number $0 < s < 1$ denote by sQ the image of Q under the mapping $(x, y, z) \mapsto (sx, sy, sz)$, and similarly for sQ_0, sQ_1 and sS . It is easy to check that if s is very close to 1, conditions (1) and (2) in the statement of this proposition are still satisfied when we replace Q, Q_0, Q_1 and S by their scaled down versions sQ, sQ_0, sQ_1 and sS . That is,

- (1') $K \cap e(sS) = K_0 \cap K_1 \subseteq e(s\dot{S})$,
- (2') $K_0 \cap e(sQ) \subseteq e(sQ_0)$ and $K_1 \cap e(sQ) \subseteq e(sQ_1)$.

The boundary of sQ is just a polyhedral sphere slightly smaller than the boundary of Q , and it is clearly bicollared in the interior of Q . Thus $e(sQ)$ is bicollared in $e(\text{int } Q)$, which is an open subset of \mathbb{R}^3 , and so $e(sQ)$ is actually bicollared in \mathbb{R}^3 . Replacing the embedding $e : Q \rightarrow \mathbb{R}^3$ by $(x, y, z) \mapsto e(sx, sy, sz)$ the result follows. ■

Now using the generalized Schönflies Theorem we see that e extends to a homeomorphism $\hat{e} : \mathbb{R}^3 \rightarrow \mathbb{R}^3$ as explained earlier. Let $h := \hat{e}^{-1}$. Applying h throughout to (1) and (2) in the statement of this proposition and cancelling any appearance of he (which is the identity by construction) it follows that the decomposition $h(K) = h(K_0) \cup h(K_1)$ satisfies (1) and (2) of Definition 9, as was to be proved. □

4. $r(T)$ WHEN T IS A TOTALLY DISCONNECTED, COMPACT SET

Throughout this section T will always denote a compact, totally disconnected subset of \mathbb{R}^3 . Recall that a set is totally disconnected if its connected components are just singletons.

As mentioned earlier, we shall say that T is rectifiable if there exists a homeomorphism of \mathbb{R}^3 that sends T into a straight line L . The following remark follows easily from this definition:

Remark 13. Let T be a compact, totally disconnected set. If T is rectifiable, then it has arbitrarily close neighbourhoods N which are unions of disjoint polyhedral 3-cells. As a consequence, $\mathbb{R}^3 - T$ is simply connected and also $r(T) = 0$.

Proof. Up to an ambient homeomorphism we may assume that T lies in a straight line L ; say the x -axis for definiteness. Notice that this does not alter the fundamental group of $\mathbb{R}^3 - T$ or the value of $r(T)$, since both are invariant under ambient homeomorphisms. Let U be a neighbourhood of T in \mathbb{R}^3 , so that $U \cap L$ is a neighbourhood of T in L . Since T is totally disconnected, it has a compact neighbourhood J in L which is a union of finitely many disjoint intervals J_1, \dots, J_n and satisfies $J \subseteq U \cap L$. This J can be thickened to obtain a pm -neighbourhood N of T in \mathbb{R}^3 simply choosing $\varepsilon > 0$ so small that $N := J \times [-\varepsilon, \varepsilon] \times [-\varepsilon, \varepsilon]$ is still contained in U . Clearly each component of N is, by construction, a polyhedral 3-cell. Letting U vary we see that T has arbitrarily close neighbourhoods N with this property. In particular, since these satisfy $H_1(N) = 0$, it follows that $r(T) = 0$. Also, the complement in \mathbb{R}^3 of any of these neighbourhoods N is simply connected, and so the same is true of the complement of T . \square

The main theorem in this section strengthens the previous remark as follows:

Theorem 14. *Let $T \subseteq \mathbb{R}^3$ be a compact, totally disconnected set. Then the following alternative holds:*

- (i) *if T is rectifiable, then $r(T) = 0$,*
- (ii) *if T is not rectifiable, then $r(T) = \infty$.*

Thus $r(T)$ cannot take any intermediate values between 0 and ∞ .

Before proving the theorem it may be instructive to examine the particular example of Antoine's necklace C , already mentioned in Section 1, because we can easily check that it is not rectifiable and also show, exploiting its self similarity properties, that $r(C) = \infty$. A detailed exposition can be found in the original paper by Antoine [1, §78, p. 311 ff.] or more modern references such as [8, pp. 42 ff.] or [19, §18, pp. 127 ff.].

Antoine's necklace is obtained as the intersection of a decreasing sequence of compact manifolds N_k each of which is a "necklace" comprised of several linked tori $T_{k,j}$. The first one, N_0 , consists of a single unknotted solid torus $T_0 \subseteq \mathbb{R}^3$. The next one, N_1 , is the union of n of solid tori $T_{1,1}, T_{1,2}, \dots, T_{1,n}$ contained in the interior of T_0 and linked as shown in Figure 5 for $n = 5$ (the drawing shows only one $T_{1,j}$ in full and just the cores of remaining tori). Place a similar (but scaled down) arrangement of n linked solid tori $T_{2,j}$ inside each of the $T_{1,j}$. Then N_2 is the union of all these second generation tori, of which there are n^2 in total. Repeating the construction inductively yields the decreasing sequence of sets N_k and their intersection $C = \bigcap_k N_k$ is Antoine's necklace. Notice that the diameter of the connected components of the N_k approaches zero as $k \rightarrow +\infty$. This implies that C is totally disconnected (in fact, it is a Cantor set).

The crucial property of C is that its complement in \mathbb{R}^3 is not simply connected. A formal proof can be found in the book by Moise [19, Theorem 4, p. 131], but it is easy to convince

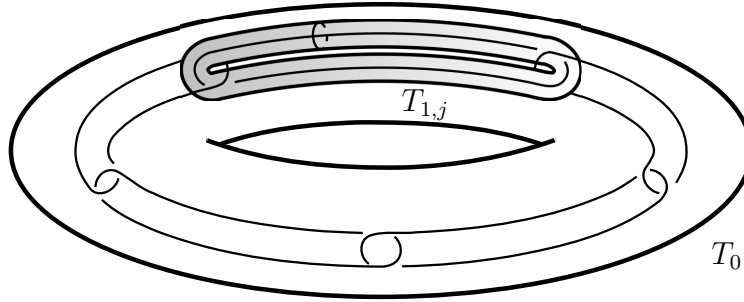

FIGURE 5.

oneself intuitively as follows. Consider a meridian μ of T_0 (contained in the surface of T_0). If we tried to contract it to a point we would surely run into some of the $T_{1,j}$ because of how they are linked to form a closed chain. On a finer scale, and for the same reason, we would also run into some of the $T_{2,j}$, and so on. Thus μ is not contractible in the complement of any of the N_k , and so it cannot be contractible in the complement of C either.

It follows from the previous paragraph and Remark 13 that C is not rectifiable. Let us check also that $r(C) = \infty$, as it should be according to Theorem 14. By the very nature of the construction of C each $T_{1,j}$ contains a Cantor set C_j that is ambient homeomorphic to all of C ; namely $C_j = C \cap T_{1,j}$. Hence $r(C) = r(C_j)$ for every $1 \leq j \leq n$. Moreover C is the disjoint union of the closed sets C_1, C_2, \dots, C_n so $r(C) = \sum_{j=1}^n r(C_j) = nr(C)$. Thus either $r(C) = 0$ or $r(C) = \infty$. Suppose $r(C) = 0$ were true. Then, by the nullity property (P4), C would have arbitrarily small pm -neighbourhoods N that are unions of 3-balls. The complement in \mathbb{R}^3 of any such neighbourhood is clearly simply connected, and therefore the same would be true of C ; that is, $\mathbb{R}^3 - C$ would be simply connected. Since this is not the case, we conclude that $r(C) \geq 1$ and so $r(C) = \infty$.

In proving Theorem 14 we shall make use of two auxiliary lemmas which we state below as Lemmas 15 and 16. Both of them can be found in a paper by Bing [3]. Although he proves them for Cantor sets, the argument applies to any compact, totally disconnected set T . Also, we warn the reader that Bing uses the more standard terminology “tame” for what we call “rectifiable” (we find the latter more expressive and, in this paper, less prone to confusion with other usages of “tame”).

Lemma 15. *Let $T \subseteq \mathbb{R}^3$ be a compact, totally disconnected set. Then T is rectifiable if, and only if, it has arbitrarily small pm -neighbourhoods N such that every component of N is a 3-cell.*

Proof. See the steps outlined in the proof of [3, Theorem 1.1, p. 435 ff.]. □

Let us say that T is *locally rectifiable* at a point $p \in T$ if there exist a neighbourhood U of p in \mathbb{R}^3 and a homeomorphism of \mathbb{R}^3 that sends $U \cap T$ into a straight line.

Lemma 16. *Let $T \subseteq \mathbb{R}^3$ be a compact, totally disconnected set. If T is locally rectifiable at every point except for, possibly, a finite set of points $F \subseteq T$, then T is rectifiable.*

Proof. See [3, Theorem 4.1, p. 440] and the remark following it. □

Now we can prove the main result of this section.

Proof of Theorem 14. Part (i) is already contained in Remark 13; we only need to prove part (ii), and we are going to establish its contrapositive. Therefore, assume that $r(T) = r < \infty$. Choose a pm -neighbourhood basis $\{N_k\}$ of T such that the following properties are satisfied:

- (N1) $N_{k+1} \subseteq \text{int } N_k$ for each k ,
- (N2) each component of every N_k meets T ,
- (N3) $\text{rk } H_1(N_k) = r$ for every k ,
- (N4) for every pm -neighbourhood N of T contained in N_1 , $\text{rk } H_1(N) \geq r$.

That such a pm -neighbourhood basis $\{N_k\}$ exists follows easily from the definition of $r(T)$. It suffices to show that T is locally rectifiable at every point $p \in T$ except for, possibly, a finite number of them; then Lemma 16 entails that T is actually rectifiable, proving the theorem. We begin with two auxiliary claims:

Claim 1. Let $\ell \geq k$. Denote by C_1, \dots, C_n the components of N_k , and for each $1 \leq i \leq n$ denote by D_{ij} (for $1 \leq j \leq m_i$) the components of N_ℓ that lie in C_i . Then, for every $1 \leq i \leq n$,

$$\text{rk } H_1(C_i) = \sum_{j=1}^{m_i} \text{rk } H_1(D_{ij}).$$

Proof. First we prove the inequality $\text{rk } H_1(C_i) \leq \sum_j \text{rk } H_1(D_{ij})$. Fix some i_0 . Consider the pm -neighbourhood N of T obtained from N_k by deleting C_{i_0} and replacing it with the D_{i_0j} . That is, let

$$N := C_1 \cup \dots \cup C_{i_0-1} \cup \underbrace{D_{i_01} \cup \dots \cup D_{i_0m_{i_0}}}_{\text{in place of } C_{i_0}} \cup C_{i_0+1} \cup \dots \cup C_n.$$

Then clearly

$$\text{rk } H_1(N) = \text{rk } H_1(N_k) - \text{rk } H_1(C_{i_0}) + \sum_{j=1}^{m_{i_0}} \text{rk } H_1(D_{i_0j}).$$

By (N3) we have $\text{rk } H_1(N_k) = r$, and by (N4) we also have $\text{rk } H_1(N) \geq r$. Replacing these above,

$$r \leq \text{rk } H_1(N) = r - \text{rk } H_1(C_{i_0}) + \sum_{j=1}^{m_{i_0}} \text{rk } H_1(D_{i_0j}),$$

which implies

$$(1) \quad \text{rk } H_1(C_{i_0}) \leq \sum_{j=1}^{m_{i_0}} \text{rk } H_1(D_{i_0j}).$$

Now observe that N_k is the disjoint union of the C_i and N_ℓ is the disjoint union of the D_{ij} , so

$$\text{rk } H_1(N_k) = \sum_{i=1}^n \text{rk } H_1(C_i) \quad \text{and} \quad \text{rk } H_1(N_\ell) = \sum_{i=1}^n \sum_{j=1}^{m_i} \text{rk } H_1(D_{ij}).$$

Since $\text{rk } H_1(N_k) = \text{rk } H_1(N_\ell) = r$ by (N3), it follows that

$$\sum_{i=1}^n \text{rk } H_1(C_i) = \sum_{i=1}^n \sum_{j=1}^{m_i} \text{rk } H_1(D_{ij}),$$

or

$$\sum_{i=1}^n \left(\text{rk } H_1(C_i) - \sum_{j=1}^{m_i} \text{rk } H_1(D_{ij}) \right) = 0.$$

The inequality (1) established above implies that each of the terms in this sum is nonpositive, so it follows that they must all be zero. This proves the claim. ■

Claim 2. Let C be a component of some N_{k_0} and assume that $\text{rk } H_1(C) = 0$. Then $C \cap T$, which is a compact and totally disconnected set, is rectifiable.

Proof. Define $N'_k := N_k \cap C$ for every $k \geq k_0$. Clearly $\{N'_k\}$ is a neighbourhood basis of $C \cap T$. Moreover, since each N'_k is nothing but the union of those components of N_k that lie in C , they are all polyhedral manifolds and so $\{N'_k\}$ is actually a pm -neighbourhood basis of $C \cap T$. Also, from Claim 1 and the hypothesis $\text{rk } H_1(C) = 0$ it follows that $\text{rk } H_1(N'_k) = 0$ for every k . Therefore $r(C \cap T) = 0$ and, by the nullity property (P4), $C \cap T$ has arbitrarily small pm -neighbourhoods N such that every component of N is a 3-ball. Thus by Lemma 15, $C \cap T$ is rectifiable. ■

Now we can complete the proof of the theorem. For each point p in T let $C(N_k; p)$ be the connected component of N_k that contains p . By Claim 1 above the sequence $\text{rk } H_1(C(N_k; p))$ decreases as k increases, so we can define

$$s(p) := \lim_{k \rightarrow \infty} \text{rk } H_1(C(N_k; p)).$$

Observe that at most r different points $p \in T$ have $s(p) \neq 0$. Indeed, suppose that at least $p_1, \dots, p_{r+1} \in T$ had $s(p_j) \geq 1$. Choose k big enough so that all the p_j lie in different components $C(N_k; p_j)$ of N_k . Evidently

$$\text{rk } H_1(N_k) \geq \sum_{j=1}^{r+1} \text{rk } H_1(C(N_k; p_j)).$$

However $\text{rk } H_1(C(N_k; p_j)) \geq s(p_j) \geq 1$ for each $1 \leq j \leq r$ (by definition of s), so we conclude that $\text{rk } H_1(N_k) \geq r + 1$, contradicting condition (N4) in the choice of $\{N_k\}$.

Now let $p \in T$ be a point for which $s(p) = 0$. We have just seen that this happens for all but finitely points in T . Since $s(p)$ is the limit of a sequence of integers, for some k_0 we have $\text{rk } H_1(C(N_k; p)) = s(p) = 0$ for $k \geq k_0$. By Claim 2 we see that $C(N_{k_0}; p) \cap T$, which is a neighbourhood of p in T , is rectifiable. Otherwise stated, T is locally rectifiable at p . Thus T is locally rectifiable at every point except for, possibly, a finite number of them, as was to be shown. □

5. A TOPOLOGICAL THEOREM

This section is devoted to the proof of the following result, whose notation and hypotheses will be tacitly assumed to hold throughout:

Theorem 17. *Let $B \subseteq \mathbb{R}^3$ be a compact 3-manifold with a connected boundary ∂B . [Notice that ∂B is a closed surface.] Suppose that ∂B contains a compact, totally disconnected set T such that ∂B is locally flat at each $p \notin T$. Then $r(B) \geq r(T)$.*

The proof involves a somewhat delicate geometric construction. In an attempt to convey the intuitive ideas as clearly as possible we have divided the explanation into three stages which we first outline and later on expand in detail.

Stage 1 Suppose $E \subseteq \partial B$ is a closed disk whose boundary ∂E does not meet T , so that ∂B is locally tame at each $p \in \partial E$. We shall show how to:

- (1) Push E slightly into B while keeping its boundary fixed, obtaining a disk \hat{E} properly embedded in B . This means that the interior of E is contained in the interior of B and the boundary of E is contained in the boundary of B .
- (2) The disk \hat{E} separates B into two connected components V_0 and V_1 such that $B = \bar{V}_0 \cup \bar{V}_1$ and $\bar{V}_0 \cap \bar{V}_1 = \hat{E}$. We choose the labeling in such a way that V_1 is the component bounded by E and \hat{E} .
- (3) The decomposition $B = \bar{V}_0 \cup \bar{V}_1$ is tame and the condition $\check{H}^1(\bar{V}_0 \cap \bar{V}_1) = 0$ needed to apply the subadditivity property (P5) of r is met. Hence $r(B) \geq r(\bar{V}_0) + r(\bar{V}_1)$.

Part (1) relies heavily on the fact that ∂B is the boundary of B and this provides a natural way of pushing E into B . It is the ultimate reason why in Theorem 2 we need to require that S bounds a 3-manifold on one side (that would be B , and then $S = \partial B$). The assumption that ∂E is disjoint from T guarantees that ∂B is locally flat at each $p \in \partial E$ and is used crucially in (3) to prove that the decomposition $B = \bar{V}_0 \cup \bar{V}_1$ is tame.

Stage 2 This is essentially the same as before, but now instead of a single disk $E \subseteq \partial B$ we consider a finite number of disjoint closed disks $E_1, \dots, E_n \subseteq \partial B$ such that none of their boundaries ∂E_j meets T . In Figure 6.(a) the set T is schematically shown as a collection of thick points in ∂B and the disks E_j as three disjoint intervals. In our actual application T will be contained in the union of the disks E_j , and that is how it is shown in Figure 6. As before, one can:

- (1) Push the disks E_j slightly into B while keeping their boundaries fixed. This yields a family of disjoint closed disks \hat{E}_j properly embedded in B . The \hat{E}_j are shown in Figure 6.(b).
- (2) The (union of the) family of disks \hat{E}_j separates B into $(n+1)$ connected components: a “big” one V_0 and “smaller” ones V_1, V_2, \dots, V_n . The latter are the ones bounded by each E_j and its corresponding \hat{E}_j (see Figure 6.(c)). As before, B is the union of the closures \bar{V}_j of the V_j . Also, $\bar{V}_1, \dots, \bar{V}_n$ are pairwise disjoint and each of them intersects \bar{V}_0 in its corresponding disk \hat{E}_j .
- (3) An argument involving the subadditivity property of r proves that the inequality

$$r(B) \geq \sum_{j=0}^n r(\bar{V}_j)$$

holds.

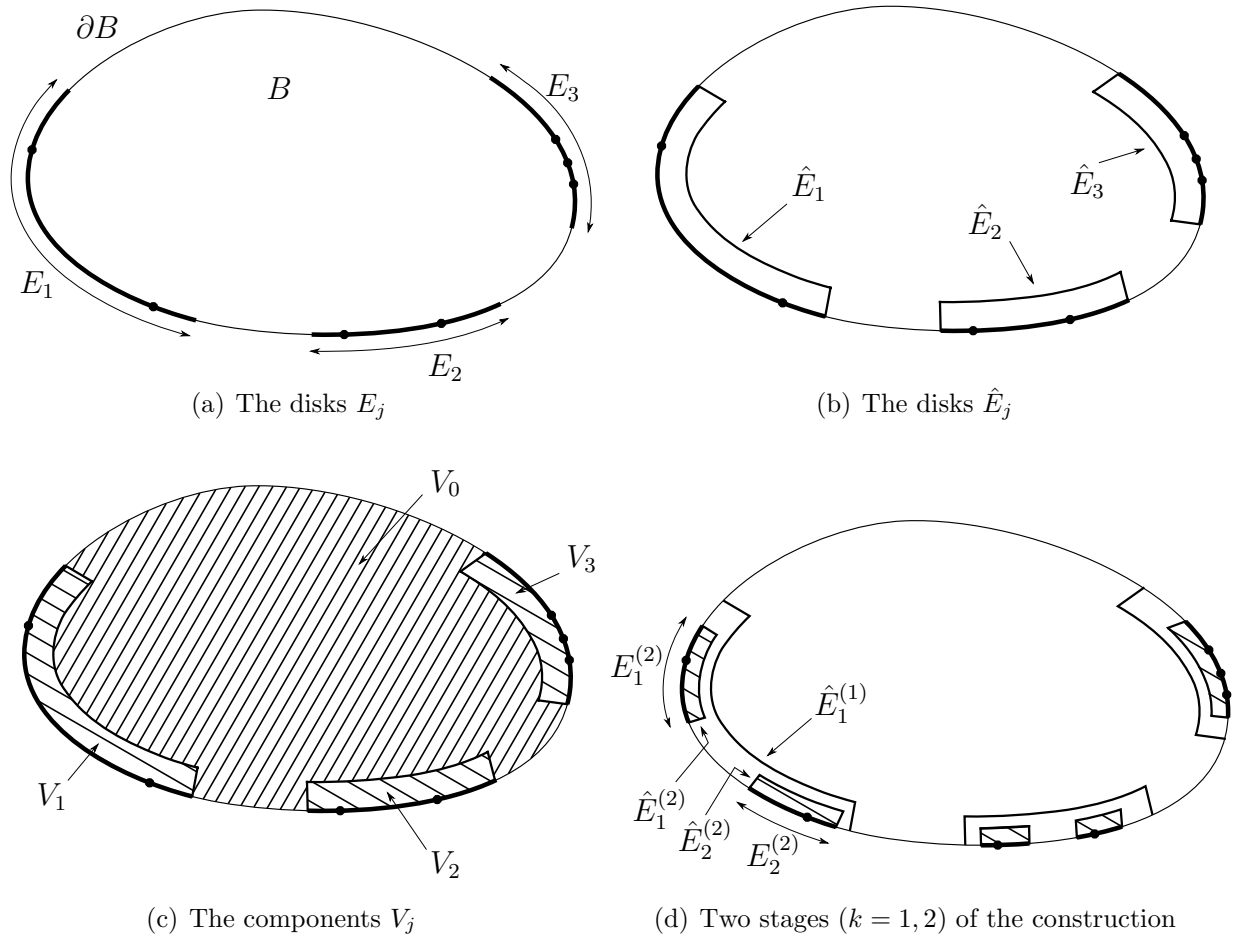

FIGURE 6.

Stage 3 Finally, instead of performing the above construction just once, we perform it for each $k = 1, 2, \dots$ as follows. At each step k , we cover T with (the interiors of) a finite family of disks $E_1^{(k)}, E_2^{(k)}, \dots, E_{n_k}^{(k)}$ which now depend on k . These disks should be chosen in such a way that each $E_j^{(k+1)}$ is contained in an $E_{j'}^{(k)}$ and their diameters tend to zero as k increases. This is always possible because T is a totally disconnected set. Then, paralleling the previous stages:

- (1) Push each disk $E_j^{(k)}$ slightly into B while keeping its boundary fixed, taking the precaution to push it only to “depth” $1/k$. See Figure 6.(d).
- (2) For each k the family of disks $E_1^{(k)}, E_2^{(k)}, \dots, E_{n_k}^{(k)}$ separates B into $(n_k + 1)$ connected components, of which we denote by $V_0^{(k)}$ the “big” one and $V_1^{(k)}, V_2^{(k)}, \dots, V_{n_k}^{(k)}$ the remaining ones.

(3) Consider the closures \bar{V}_j of the V_j . As before, the inequality

$$r(B) \geq \sum_{j=0}^{n_k} r(\bar{V}_j^{(k)})$$

holds for each k . For the sake of brevity, set

$$B_0^{(k)} := \bar{V}_0^{(k)} \quad \text{and} \quad B_1^{(k)} := \bar{V}_1^{(k)} \cup \dots \cup \bar{V}_{n_k}^{(k)}.$$

Since $\bar{V}_1^{(k)}, \dots, \bar{V}_{n_k}^{(k)}$ are mutually disjoint, clearly $r(B_1^{(k)})$ coincides with the sum $\sum_{j=1}^{n_k} r(\bar{V}_j^{(k)})$ and therefore the above inequality can be written more compactly as

$$r(B) \geq r(B_0^{(k)}) + r(B_1^{(k)}).$$

(4) From the above inequality we have $r(B) \geq r(B_1^{(k)})$ for every k . Since each $E_j^{(k+1)}$ is contained in some $E_{j'}^{(k)}$ and we have pushed $E_j^{(k+1)}$ into B to depth $1/(k+1)$, which is less than we did with $E_{j'}^{(k)}$, it follows that $V_j^{(k+1)}$ is contained in $V_{j'}^{(k)}$ as suggested by Figure 6.(d). As a consequence, $B_1^{(k+1)} \subseteq B_1^{(k)}$. Moreover, since the diameters of the $E_j^{(k)}$ and the depths $1/k$ of the $\hat{E}_j^{(k)}$ converge to zero, $T = \bigcap_{k=1}^{\infty} B_1^{(k)}$. Then, appealing to the semicontinuity property (P3) of r and using $r(B) \geq r(B_1^{(k)})$, we get

$$r(B) \geq \liminf_{k \rightarrow \infty} r(B_1^{(k)}) \geq r(T)$$

which proves Theorem 17.

In the remaining of this section we shall fill in the details of the proof of Theorem 17 along the lines just described. We shall begin with a ‘‘Stage 0’’ in order to introduce some notation and constructions that will be useful later on. Also, we shall use without explanation some facts that follow from the two dimensional Schönflies Theorem. It was mentioned earlier, just after the statement of Proposition 12, that in three dimensions the Schönflies Conjecture is false in general; some additional condition (such as the sphere being bicollared) is needed. However, in two dimensions the conjecture is true without any additional assumptions: given any two 1–spheres in \mathbb{R}^2 (that is, any two simple closed curves in the plane) there is an ambient homeomorphism that takes one onto the other (see [19, Chapter 10, pp. 71 ff.]). As a consequence, given any two closed disks in the plane there is always an ambient homeomorphism that sends one onto the other. This form of the result generalizes, in fact, to any connected surface: given any two closed disks E and E' in a closed connected surface S , there is a homeomorphism of the surface that sends one onto the other. In particular, let $E' := \varphi^{-1}(\mathbb{D}^2)$ where $\varphi : U \subseteq S \rightarrow \mathbb{R}^2$ is some chart of S and \mathbb{D}^2 is the closed unit disk in \mathbb{R}^2 . As just mentioned, by the two dimensional Schönflies Theorem there is a homeomorphism g of S that sends E onto E' . The composition $\varphi \circ g$ is defined on the neighbourhood $g^{-1}(U)$ of E and sends E onto $\mathbb{D}^2 \subseteq \mathbb{R}^2$, allowing us to pull back any construction performed with \mathbb{D}^2 to a construction performed with E . For instance: (i) one can clearly find arbitrarily thin annuli along $\partial\mathbb{D}^2$; pulling back via $\varphi \circ g$, the same is true of ∂E ; (ii) one can clearly find arbitrarily small neighbourhoods of \mathbb{D}^2 that are homeomorphic to \mathbb{R}^2 (for instance, open disks with radius slightly bigger than 1 but arbitrarily close to it), so the same is true of E .

5.1. **Stage 0.** Consider the plane $\{z = 0\}$ in \mathbb{R}^3 and a closed disk $D \subseteq \{z = 0\}$. Define $P := \mathbb{R}^2 \times [-2, 2]$ and $P^+ := \mathbb{R}^2 \times [0, 2]$. Set

$$(2) \quad \hat{D} := \partial D \times [0, 1] \cup D \times 1.$$

(To avoid ambiguities in interpreting this and subsequent expressions we adhere to the convention that ∂ has precedence over \times , which in turn has precedence over \cup and $-$). See Figure 7. Clearly \hat{D} is a 2-disk whose boundary coincides with ∂D and whose interior is entirely contained in the upper halfspace $z > 0$; that is, \hat{D} is properly embedded in P^+ . We say that \hat{D} has been obtained by *pushing* D into P^+ to *depth one*. Notice that \hat{D} separates P^+ into two connected components

$$(3) \quad U_0 := \mathbb{R}^2 \times (1, 2] \cup (\mathbb{R}^2 - D) \times [0, 2] \quad \text{and} \quad U_1 := \hat{D} \times [0, 1)$$

whose intersection is precisely the disk \hat{D} . Here (and in the sequel) a dot over a manifold will denote the interior of the manifold (that is, the manifold minus its boundary). That \hat{D} separates P^+ as described should be clear intuitively and can be confirmed by Figure 7.

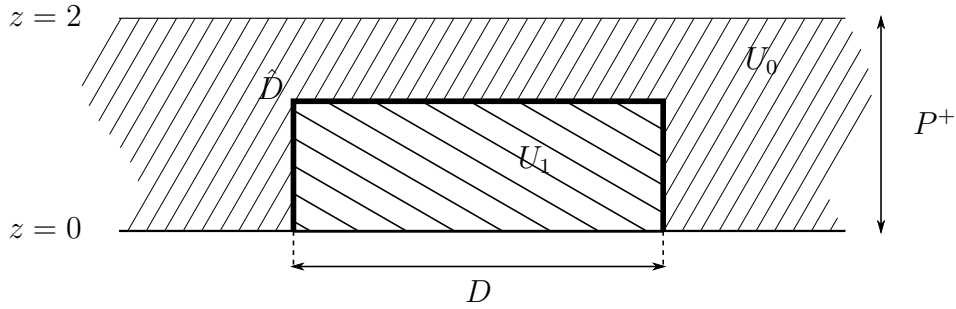

FIGURE 7. The construction of \hat{D}

Although it does not really make sense to say that the decomposition $P^+ = U_0 \cup U_1$ is tame because P^+ is not compact, the way in which the sets U_0 and U_1 intersect along \hat{D} is certainly characteristic of tame decompositions. This is the motivation behind the following proposition, where we make use again of the sets Q , S , Q_0 and Q_1 introduced when discussing the subadditivity property, just before Figure 4.

Proposition 18. *There exists an embedding $e : Q \rightarrow \mathbb{R}^3$ such that:*

- (1) $\hat{D} \subseteq e(\dot{S})$,
- (2) $U_0 \cap e(Q) \subseteq e(Q_0)$ and $U_1 \cap e(Q) \subseteq e(Q_1)$.

Figure 8 below illustrates the content of Proposition 18 in a two dimensional (very schematic) picture. We have denoted $S' = e(S)$ and $Q' = e(Q)$. S' separates Q' into two connected components whose closures are precisely $e(Q_0)$ and $e(Q_1)$.

Proof. Let A be a closed annulus along the boundary of D . Consider the sets

$$S' := \partial D \times [-1, 1] \cup D \times 1 \quad \text{and} \quad Q' := A \times [-1, 3/2] \cup D \times [1/2, 3/2].$$

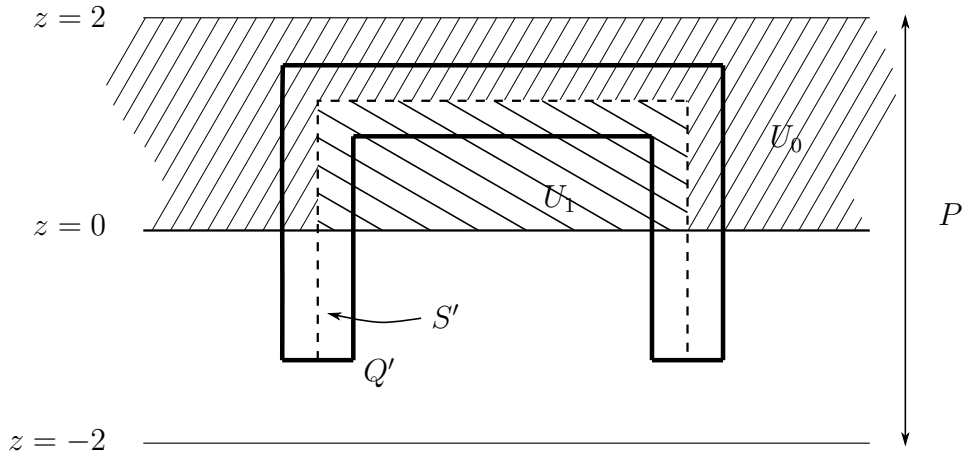

FIGURE 8. Scheme for Proposition 18

Q' resembles a “thick bucket” turned upside down. Its intersection with the plane $\{z = 0\}$ is precisely the annulus A . S' is a 2-disk properly embedded in Q' . The intersection of S' with the plane $\{z = 0\}$ is precisely the boundary of the disk D . The disk \hat{D} is the part of S' that lies above the $\{z = 0\}$ plane; that is, the intersection $S' \cap \{z \geq 0\}$. In particular \hat{D} is contained in the interior of S' .

Simple case. First consider the particular case when D is a square and A is the annulus comprised between two homothetic copies of D , one slightly bigger and the other slightly smaller than D itself. Figure 9 shows how Q' and S' would look in this case. S' separates Q' into two connected components, the closures of which we denote by Q'_0 and Q'_1 . Specifically, we let Q'_0 denote the closure of the “outer” component and Q'_1 the closure of the “inner” one.

It is easy to see that there exists a homeomorphism e from Q onto Q' that sends S onto S' . We specify e as follows. Label the vertices of the bottom, annular face of Q' with the letters A_1, \dots, A_4 and B_1, \dots, B_4 as suggested in Figure 9.(a) (not all the labels are shown in the drawing to avoid cluttering). Then, referring to Figures 4 and 9.(a), the homeomorphism e may be described by saying that it is piecewise linear and has the following properties:

- (i) The vertices of the left face of Q are mapped onto the A_i while the face itself is mapped onto the outer surface of Q' ; that is, onto the lateral outer walls and the top outer face.
- (ii) The vertices of the right face of Q are mapped onto the B_i ; the face itself is mapped onto the inner surface of Q' .
- (iii) A thin annular neighbourhood along ∂S in ∂Q is mapped onto the bottom annular face of Q' .

Evidently e sends Q_0 onto Q'_0 and Q_1 onto Q'_1 . Hence $U_0 \cap e(Q) = U_0 \cap Q' \subseteq e(Q_0)$ and similarly $U_1 \cap e(Q) = U_1 \cap Q' \subseteq e(Q_1)$ (the U_i were defined in Equation (3)), showing that e satisfies condition (2). Also, $e(\hat{S})$ is the interior of $e(S) = S'$, so condition (1) is also satisfied because $\hat{D} \subseteq \hat{S}'$ by construction.

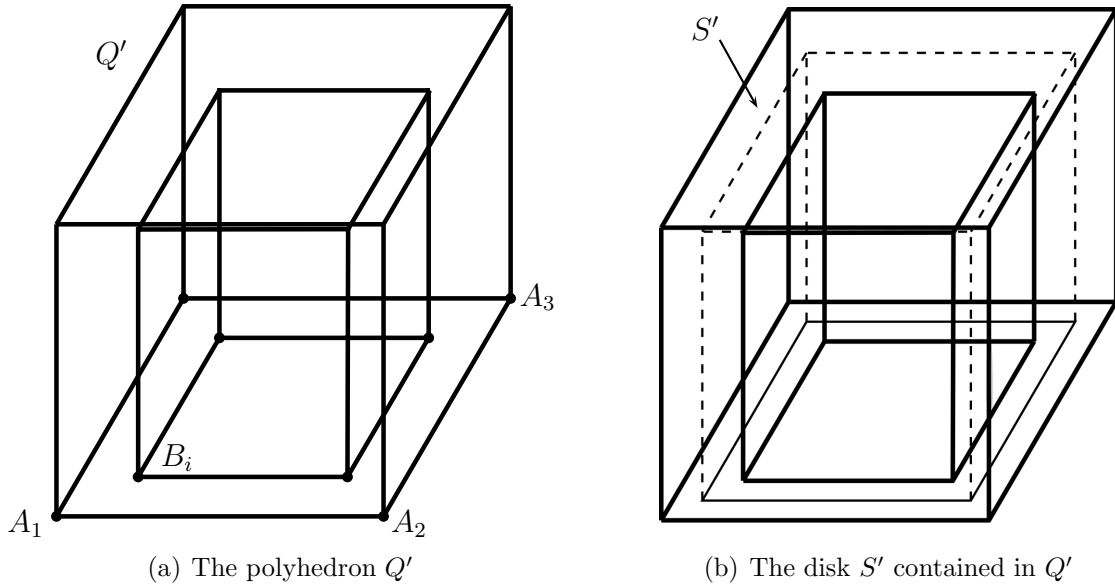

FIGURE 9.

General case. When D is an arbitrary disk we can appeal to the two dimensional Schönflies Theorem to reduce the problem to the previous case. Indeed, the Schönflies Theorem guarantees that there exists a homeomorphism $s : \{z = 0\} \rightarrow \{z = 0\}$ that sends D onto a square D_0 for which we already know an embedding e_0 exists with the required properties, as constructed in the previous case. Clearly s extends to a homeomorphism \hat{s} of all \mathbb{R}^3 simply letting $\hat{s}(x, y, z) := (s(x, y), z)$, and it is then easy to check that the embedding $e := \hat{s} \circ e_0$ satisfies all the required conditions. \square

Later on we shall need the explicit form of $Q' = e(Q)$ used in the proof of the proposition. Hence, for future reference, we record it here:

$$(4) \quad Q' := A \times [-1, 3/2] \cup D \times [1/2, 3/2],$$

where A is a closed annulus along the boundary of D .

5.2. Stage 1. We need to recall some standard definitions (see for instance [5]) which expand on the notion of bicollared spheres discussed after the statement of Proposition 12. Suppose Y is a subspace of X . We say that Y is *collared* in X if there exists a homeomorphism c from $Y \times [0, 1]$ onto a neighbourhood of Y in X and such that $c(p, 0) = p$ for every $p \in Y$, and *locally collared* at some point $p \in Y$ if p has a neighbourhood in Y which is collared in X . We shall make use of two important theorems of Brown:

- (B1) If Y is locally collared in X at each $p \in Y$, then Y is collared in X [5, Theorem 1, p. 337].
- (B2) As a consequence, the boundary ∂X of a manifold with boundary X is collared in the manifold [5, Theorem 2, p. 339].

Suppose S is a closed surface contained in \mathbb{R}^3 . A *bicollar* of S is a homeomorphism b from $S \times [-1, 1]$ onto a neighbourhood of S in \mathbb{R}^3 such that $b(p, 0) = p$ for every $p \in S$ (this is

a trivial extension of the definition given earlier for 2–spheres). The existence of a bicollar is equivalent to the existence of a collar of S both in \bar{U} and \bar{V} , where U and V are the two connected components into which S separates \mathbb{R}^3 . When S bounds a 3–manifold, as with ∂B in our context, then at least one of the complementary domains of S (say \bar{U}) is a 3–manifold whose boundary is precisely S , so S is already collared “on the U -side” and consequently it is bicollared if and only if it is collared also “on the V -side”.

Given a point $p \in S$ one defines the notion of S being *locally bicollared* at p mimicking the definition of locally collared given earlier. It is not difficult to check that if S is locally flat at some point p , then it is locally bicollared at that same point (the converse is also true, but we shall not need it).

Let E be a closed disk contained in the boundary of B and such that ∂E is disjoint from T so, in particular, ∂B is locally flat at each point of ∂E .

First let us show how to push E into B , essentially mimicking the model laid out in Section 5.1. Since ∂B is collared in B by (B2), there exists an embedding c^+ of $\partial B \times [0, 2]$ into B such that $c^+(p, 0) = p$ for every $p \in \partial B$. (Notice that we take $\partial B \times [0, 2]$ rather than $\partial B \times [0, 1]$ as the domain of the collar c^+ ; this is just for notational convenience.) Denote by C the image of c^+ , which is a closed neighbourhood of ∂B in B . Set

$$(5) \quad \hat{E} := c^+(\partial E \times [0, 1] \cup E \times 1).$$

By construction \hat{E} is a 2–disk properly embedded in B ; also, $\partial \hat{E} = \partial E$. At this point it may be convenient to refer back to Figure 6.(b), which shows a two dimensional sketch of the situation. The disk E appears as an interval contained in the boundary of B , and \hat{E} can be thought of as the result of pushing E into B along the lines of the collar c^+ .

Proposition 19. *Suppose B is connected. Then \hat{E} separates B into two connected components V_0 and V_1 such that $E \cap V_0 = \emptyset$, $\hat{E} \subseteq V_1$ and $\bar{V}_0 \cap \bar{V}_1 = \hat{E}$.*

Proof. Let $C/2$ denote “half the collar C ”; that is, $C/2 := c^+(\partial B \times [0, 1])$. Consider the sets

$$V_0 := (B - C/2) \cup c^+(\partial B - E \times [0, 2]) \quad \text{and} \quad V_1 := c^+(\hat{E} \times [0, 1]).$$

Both are open in B , and both are connected: V_1 clearly so, and V_0 because it is the union of two connected sets having a nonempty intersection. Indeed, $B - C/2$ is homeomorphic to the interior of B , which is connected because B is connected (in \mathbb{R}^3 , the assumption that ∂B is connected entails that B is connected too), and $\partial B - E$ is connected because removing a disk from a (by assumption) connected surface does not disconnect the surface. Also, V_0 and V_1 are disjoint and their union is $B - \hat{E}$, so they are actually the two connected components into which \hat{E} separates B . A straightforward computation shows that $\bar{V}_0 = V_0 \cup \hat{E}$ and $\bar{V}_1 = V_1 \cup \hat{E}$, so $\bar{V}_0 \cap \bar{V}_1 = \hat{E}$. By construction clearly V_0 does not meet E whereas $\hat{E} \subseteq V_1$. \square

Now we want to show that the decomposition $B = \bar{V}_0 \cup \bar{V}_1$ is tame. To this end we need to construct some sort of “partial bicollar” of E in \mathbb{R}^3 as described below.

The “inner half” of the bicollar (that is, the part contained in B) presents no difficulty since ∂B itself (hence E) is collared in B . In fact, we already made use of it when constructing the disk \hat{E} . We therefore keep our previous notation: $c^+ : \partial B \times [0, 2] \rightarrow B$ is an embedding such that $c^+(p, 0) = p$ for every $p \in \partial B$.

Denote by B' the complement (in \mathbb{R}^3) of the interior of B ; that is, $B' := \mathbb{R}^3 - \dot{B}$. The “outer half” of the bicollar (the part contained in B') can be constructed along ∂E , since it contains no wild points of ∂B by assumption. More precisely, we proceed as follows. At each $p \in \partial E$ the surface ∂B is locally flat, hence locally bicollared and in particular locally collared in B' . Thus, every $p \in \partial E$ has a neighbourhood W_p in ∂B over which it is possible to find a local collar $c_p^- : W_p \times [-1, 0] \rightarrow B'$. Since ∂E is compact, we may cover it with a finite family of these W_p and paste all the collars together using the result of Brown cited above (B1) to obtain a collar $c^- : W \times [-1, 0] \rightarrow B'$, where W is a neighbourhood of ∂E in ∂B .

Notice that ∂E is a simple closed curve and so it has arbitrarily close neighbourhoods A that are closed annuli along the curve ∂E . Finding such an A so thin that it is contained in W we can assume that the collar c^- is defined on all of A . The union $b := c^+ \cup c^-$ thus provides an embedding

$$b : A \times [-1, 2] \cup E \times [0, 2] \rightarrow \mathbb{R}^3.$$

Proposition 20. *The decomposition $B = \bar{V}_0 \cup \bar{V}_1$ is tame. Thus, the inequality $r(B) \geq r(\bar{V}_0) + r(\bar{V}_1)$ holds.*

Proof. We are going to use the criterion of Proposition 12 (thus Q , S , Q_0 and Q_1 have the meaning given there).

By the two dimensional Schönflies Theorem, there exists a homeomorphism g_0 of the plane $\{z = 0\}$ onto an open neighbourhood of $E \cup A$ in ∂B . Let D and A_0 be the pullbacks of E and A via g_0 ; that is, $D := g_0^{-1}(E)$ and $A_0 := g_0^{-1}(A)$. These are a closed disk in $\{z = 0\}$ and an annulus along its boundary, respectively.

As in Stage 0, push D into P^+ to depth 1 obtaining $\hat{D} := \partial D \times [0, 1] \cup D \times 1$. Also, consider the cube $Q' := A_0 \times [-1, 2] \cup D \times [0, 2]$ (compare with Equation (4)). The map g_0 can be extended to an embedding g of all of Q' into \mathbb{R}^3 using the partial bicollar b , letting $g(x, y, z) := b(g_0(x, y), z)$. Notice that, by construction:

- (i) g takes \hat{D} onto \hat{E} ,
- (ii) $g(U_0 \cap Q') \subseteq V_0$ and $g(U_1 \cap Q') = V_1$, where V_0 and V_1 are the connected components of $B - \hat{E}$.

According to Proposition 18 and the form of $Q' = e(Q)$ given in Equation (4) there exists a homeomorphism $e : Q \rightarrow Q'$ such that:

- (1) $\hat{D} \subseteq e(\hat{S})$,
- (2) $U_0 \cap e(Q) \subseteq e(Q_0)$ and $U_1 \cap e(Q) \subseteq e(Q_1)$.

Consider the embedding $e' := g \circ e : Q \rightarrow \mathbb{R}^3$. Applying g to both sides of (1) and using (i) we see that $\hat{E} \subseteq e'(\hat{S})$. Doing the same with (2) and (ii) it follows that $V_0 \cap e'(Q) \subseteq e'(Q_0)$ and $V_1 \cap e'(Q) \subseteq e'(Q_1)$. This establishes (1) and (2) of Proposition 12, proving that the decomposition $B = \bar{V}_0 \cup \bar{V}_1$ is tame. □

Remark 21. Notice that in constructing \hat{E} there is nothing special in pushing E into B to “depth 1”; that is, we could set

$$\hat{E} := c^+(\partial D \times [0, \epsilon] \cup E \times \epsilon)$$

for any $0 < \epsilon < 1$ and everything would work just as well (with the appropriate modifications to the definitions of D , S' and Q'). For later reference we shall call this “pushing E into B down to depth ϵ ”. Also, observe that the collar c^+ can be fixed once and for all; it does not depend on the disk E being considered. The same is not true of c^- , since it was constructed pasting local collars along ∂E .

5.3. Stage 2. Let now E_1, E_2, \dots, E_n be disjoint closed disks in ∂B whose boundaries do not meet T . Push each E_j into B while leaving its boundary untouched. This is done exactly as described in 5.2 for a single disk: having chosen a collar $c^+ : \partial B \times [0, 2] \rightarrow B$, we consider the family of disjoint disks

$$\hat{E}_j := c^+(\partial E_j \times [0, 1] \cup E_j \times 1);$$

all of them properly embedded in B . Arguing as in Proposition 19 one sees that the (union of the) disks $\hat{E}_1, \hat{E}_2, \dots, \hat{E}_n$ separate B into $n + 1$ connected components V_0, V_1, \dots, V_n . We label them in such a way that V_0 does not meet any of the E_j whereas $\hat{E}_j \subseteq V_j$ for each $1 \leq j \leq n$. More explicitly

$$V_0 := (B - C/2) \cup c^+(\partial B - \cup_j E_j \times [0, 2]) \quad \text{and} \quad V_j := c^+(\hat{E}_j \times [0, 1)) \quad \text{for } j = 1, 2, \dots, n;$$

here $C/2$ is the “half collar” introduced in the proof of Proposition 19. The V_j satisfy the following properties:

- (V1) $\hat{E}_j \subseteq V_j$ for each $j = 1, \dots, n$
- (V2) $\bar{V}_i \cap \bar{V}_j = \emptyset$ for $1 \leq i \neq j \leq n$
- (V3) $\bar{V}_0 \cap \bar{V}_j = \hat{E}_j$ for each $j = 1, \dots, n$

Proposition 22. *The inequality $r(B) \geq \sum_{j=0}^n r(\bar{V}_j)$ holds.*

Proof. Consider the ascending sequence of compact sets

$$K_j := \bar{V}_0 \cup \bar{V}_1 \cup \dots \cup \bar{V}_j$$

for $0 \leq j \leq n$. Notice that $K_{j+1} := K_j \cup \bar{V}_{j+1}$ and $K_j \cap \bar{V}_{j+1} = \bar{V}_0 \cap \bar{V}_{j+1} = \hat{E}_{j+1}$ by (V2) and (V3). The same argument of Proposition 20 (enlarging the disk \hat{E}_{j+1} using the fact that its boundary does not contain any wild points) shows that the decomposition $K_{j+1} = K_j \cup \bar{V}_{j+1}$ is tame, and so entails that $r(K_{j+1}) \geq r(K_j) + r(\bar{V}_{j+1})$. Inductively, this gives

$$r(K_n) \geq r(K_0) + \sum_{j=1}^n r(\bar{V}_j).$$

It only remains to observe that $K_0 = \bar{V}_0$ (this is clear) and $K_n = \bar{V}_0 \cup \bar{V}_1 \cup \dots \cup \bar{V}_n$ is the whole B : indeed, by definition the union of the V_j is $B - \cup \hat{E}_j$; since (V3) guarantees that \bar{V}_0 contains all the \hat{E}_j , it follows that the union of the \bar{V}_j is all of B . \square

5.4. Stage 3. We are finally ready to put all the pieces together and prove Theorem 17:

Proof of Theorem 17. From the fact that T is totally disconnected it is easy to prove (or see [19, Theorem 6, p. 72 and Theorem 5, p. 93]) that it has arbitrarily small neighbourhoods in ∂B that are unions of a finite number of disjoint disks. Thus for $k = 0, 1, 2, \dots$ we may construct a sequence of neighbourhoods $E^{(k)}$ of T in ∂B such that

- (E1) each $E^{(k)}$ is a union of disjoint disks $E_1^{(k)}, E_2^{(k)}, \dots, E_{n_k}^{(k)}$,
- (E2) $E^{(k+1)}$ is contained in the interior of $E^{(k)}$ for every k ,
- (E3) the intersection $\bigcap_k E^{(k)}$ is precisely T .

For each k apply the construction described in 5.3 to the family of disks $E_1^{(k)}, E_2^{(k)}, \dots, E_{n_k}^{(k)}$. This involved a choice of a collar c^+ of ∂B in B ; this is to be made once and used for every k as mentioned in Remark 21. Also (again, refer to Remark 21) we can push the disks $E_j^{(k)}$ into B only to depth $\epsilon = 1/k$. The resulting disks $\hat{E}_1^{(k)}, \hat{E}_2^{(k)}, \dots, \hat{E}_{n_k}^{(k)}$ separate B into $n_k + 1$ connected components $V_0^{(k)}, V_1^{(k)}, \dots, V_{n_k}^{(k)}$ of which the ones of interest to us are

$$V_j^{(k)} = c^+(\hat{E}_j^{(k)} \times [0, 1/k]) \quad j = 1, 2, \dots, n_k.$$

Condition (E2) on the $E^{(k)}$ implies that each disk $E_j^{(k+1)}$ is contained in some disk $E_{j'}^{(k)}$. Since c^+ is independent of k , this entails that each $V_j^{(k+1)}$ is contained in some $V_{j'}^{(k)}$. Set

$$B_0^{(k)} := \bar{V}_0^{(k)} \quad \text{and} \quad B_1^{(k)} := \bigcup_{j=1}^{n_k} \bar{V}_j^{(k)}.$$

From what we just said, $B_1^{(k+1)} \subseteq B_1^{(k)}$ for each k . Also, (E3) and the condition that the disks $\hat{E}_j^{(k)}$ are obtained by pushing $E_j^{(k)}$ only to depth $1/k$ implies that $\bigcap_k B_1^{(k)} = T$. Finally, Proposition 22 shows that

$$r(B) \geq \sum_{j=0}^{n_k} r(\bar{V}_j^{(k)}) \geq \sum_{j=1}^{n_k} r(\bar{V}_j^{(k)}) = r(B_1^{(k)})$$

where in the last step we have used the trivial fact that r of a disjoint union of finitely many compact sets is the sum of their r numbers. Now from the semicontinuity of r and the fact that the $B_1^{(k)}$ decrease and have T as their intersection it follows that

$$r(B) \geq \liminf_{k \rightarrow \infty} r(B_1^{(k)}) \geq r(T).$$

This concludes the proof of Theorem 17. □

6. THE PROOF OF THEOREM 2 AND COROLLARY 3

All the work done so far makes the proof of the following result very short:

Theorem 23. *Let $B \subseteq \mathbb{R}^3$ be a compact 3-manifold with a connected boundary ∂B . Suppose that ∂B contains a compact, totally disconnected set T such that:*

- (i) T is not rectifiable.
- (ii) ∂B is locally flat at each $p \notin T$.

Then B cannot be realized as an attractor for a homeomorphism of \mathbb{R}^3 .

Proof. By Theorems 17 and 14 we have $r(B) \geq r(T) = \infty$, so $r(B) = \infty$. Then the finiteness property (P1) of r (see p. 8) shows that B cannot be an attractor for a homeomorphism. □

From this,

Proof of Theorem 2. Suppose that the closed and connected surface S were an attractor for a homeomorphism f of \mathbb{R}^3 . Think of \mathbb{S}^3 as \mathbb{R}^3 together with the point at infinity ∞ and extend f to all of \mathbb{S}^3 letting $f(\infty) := \infty$. Viewing S as a subset of \mathbb{S}^3 , it is still an attractor for f with the same basin of attraction.

Let U_1 and U_2 be the connected components of $\mathbb{S}^3 - S$. Since S bounds a 3-manifold by hypothesis, the closure (in \mathbb{R}^3 and also in \mathbb{S}^3) of at least one of the \bar{U}_i is a 3-manifold. Call it B . Since S is invariant under f , so is $\mathbb{S}^3 - S$ and therefore f either leaves each U_i invariant or interchanges them. However, only one of the U_i contains ∞ , which is fixed by f , so it must be the case that $f(U_i) = U_i$. As a consequence $f(B) = B$, so that B is also invariant under f . It is straightforward to check that B is an attractor for f . Also, by definition B is a compact 3-manifold whose boundary is precisely $\partial B = S$. Applying Theorem 23 to B we see that T has to be rectifiable, and so Theorem 2 follows. \square

The alternative form of Theorem 2' is an immediate consequence of this:

Proof of Theorem 2'. Being a compact manifold, S has finitely many connected components S_i each of which is a closed surface. Also, all the S_i bound a 3-manifold on one side because S does. Since each S_i is open in S , the surface S is locally flat at some $p \in S_i$ if and only if S_i is locally flat at p . Therefore the set of wild points W of S is the union of the sets W_i of wild points of the S_i . Finally, it is proved in [23] that each component of an attractor in \mathbb{R}^n is an attractor itself. Thus all the S_i are attractors, and applying the contrapositive of Theorem 2 to them (with $T = W_i$ in each case) it follows that each W_i must be rectifiable. Since the W_i are open in W and cover it, W is locally rectifiable and, by Lemma 16, rectifiable. \square

We saw in Remark 13 that a rectifiable totally disconnected set has a simply connected complement in \mathbb{R}^3 . Thus we may state the following, more computational consequence of Theorem 2:

Corollary 24. *Let $S \subseteq \mathbb{R}^3$ be a closed surface that bounds a 3-manifold. Suppose that S contains a closed, totally disconnected set T such that (i) S is locally flat at each $p \notin T$ and (ii) the complement of T in \mathbb{R}^3 is not simply connected. Then S cannot be an attractor.*

We finish by proving that there are uncountably many non equivalent ways of embedding a 2-sphere in \mathbb{R}^3 in such a way that it cannot be an attractor (Corollary 3). It will be evident from the proof that the corollary is true for (orientable) surfaces of any genus. However, for surfaces of higher genus (think, for instance, of a torus) one can obtain trivially nonequivalent embeddings by knotting the surface differently in \mathbb{R}^3 . Concentrating on spheres we avoid this degree of freedom, which is not interesting in the present context.

Let us review the construction of nonattracting surfaces described in Section 1. We start with a compact 3-manifold B_0 , which in our present case is going to be the unit closed 3-ball, and extract feelers that branch in such a way as to (in the limit) reach a prescribed non rectifiable, compact, totally disconnected set T . The branching process is guided by a sequence of neighbourhoods N_k of T chosen in advance. The resulting compact 3-manifold B is still homeomorphic to the original B_0 , and its boundary S (which is, accordingly, homeomorphic to S_0) is locally flat at each $p \notin T$. Then Theorem 2 immediately implies that S cannot be an attractor.

Although for our purposes in Section 1 we did not need to fully identify the set W of wild points of S (it was enough to know that $W \subseteq T$), now we need to be a little more precise and guarantee that $W = T$. In general this equality does not need to hold: for instance, if T has an isolated point p and its corresponding feeler converges “straight” towards p (think of a cone having p at its tip) then p is not a wild point.

There are several ways to refine the above construction in order to guarantee that $W = T$. One of them is to require that T be *homogeneous*; that is, for any two $p, q \in T$ there exists a homeomorphism of \mathbb{R}^3 that sends p onto q . It is not difficult to prove that: (i) if S is locally flat at some $p \in T$, then T is locally rectifiable at p (essentially because every compact, totally disconnected set in the plane is rectifiable; see Chapter 13 in [19]); (ii) due to the homogeneity of T , if it is locally rectifiable at a single point then it is locally rectifiable at every point. Since T is non rectifiable, (i), (ii) and Lemma 16 entail that $W = T$.

A less simple but perhaps more illustrative way of achieving the equality $W = T$ consists in patterning the feelers that are used to enlarge B_0 after the wild arc α shown in Figure 10.(a), due to Fox and Artin. By “patterning the feeler along α ” we mean that the feeler is obtained by thickening α to a solid tube whose diameter tapers towards zero as it approaches p , as shown in Figure 10.(b). An arc is tame if it can be sent into a straight line segment by an ambient homeomorphism, or wild otherwise. That α is wild was established by Fox and Artin [10, Example 1.2, pp. 983 ff.] performing a local analysis of the fundamental group of $\mathbb{R}^3 - \alpha$ near p . More specifically, they showed that α is not 1-LCC at p , which it would be if it were tame (see [8, Section 2.8, pp. 75 ff.] for more details). We remark, because it will play a role later on, that an arc $\beta \subseteq \mathbb{R}^3$ that is actually contained in a plane within \mathbb{R}^3 is 1-LCC at each of its points because there are no wild arcs in two dimensions ([19, Chapter 10, pp. 59 ff.]).



FIGURE 10.

In the actual construction of S we need to branch feelers into smaller subfeelers, of course, but we want to preserve their “Fox-Artin nature”. Figure 11 suggests how this is done. As illustrated in Figure 11.(a) suppose that, just after crossing the boundary of some N_k (recall that these are the neighbourhoods of T that are used to guide the branching process), we need to split the incoming feeler into, say (for simplicity), two subfeelers that will eventually converge to two different points p and p' of T . We continue as in Figure 11.(b), simply patterning each subfeeler after the Fox-Artin arc α . However, this is not all: we insist that the subfeelers are tangled with the original feeler in the characteristic fashion of α , as shown for the lower subfeeler in Figure 11.(c). The upper subfeeler (the one leading to p') should also be tangled with its parent feeler in the same way, although this is not shown in the drawing to avoid cluttering it.

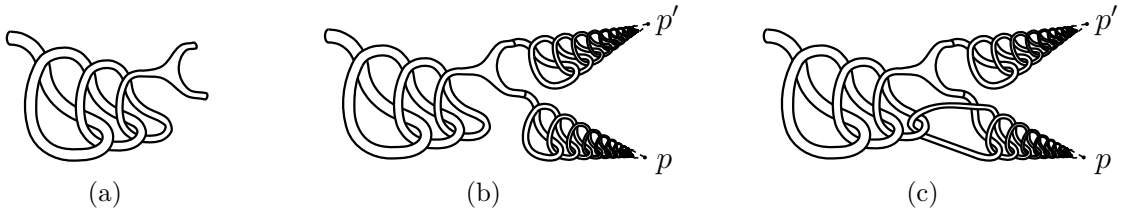

FIGURE 11. Branching a Fox–Artin feeler

This last step guarantees that, for each $p \in T$, there is a Fox–Artin arc α_p which looks exactly like α (in particular, it is also a wild arc) that starts at any prescribed point in B_0 and ends at p , running along the boundary of B (that is, along the surface S) and choosing at each branching point the appropriate subfeeler to reach p . In turn, this entails that S cannot be locally flat at p . For, suppose it were. Then locally near p the surface S would look like a plane in \mathbb{R}^3 , and α_p (again, near p) would be contained in that plane. But we mentioned earlier that there are no wild curves in two dimensions and, in particular, α_p would be 1–LCC at p , which it is not. Thus, summing up, we have proved the following:

Remark 25. If the construction of Section 1 is performed using Fox–Artin feelers as just described, the set of wild points of the resulting surface is all of T .

(Incidentally, maybe after seeing this argument Remark 4.(1) becomes more convincing). With Remark 25 and a result of Sher we can now easily prove Corollary 3; that is, we can show that there exist uncountably many 2–spheres S_i in \mathbb{R}^3 such that: (i) none of the S_i can be realized as an attractor and (ii) for $i \neq j$ the spheres S_i and S_j are not ambient homeomorphic.

Proof of Corollary 3. Sher proved [27, Corollary 1, p. 1199] that there exists an uncountable family $\{T_i\}_{i \in I}$ of Cantor sets in \mathbb{R}^3 that are all inequivalently embedded; that is, for any two different $i, j \in I$ there is no ambient homeomorphism sending T_i onto T_j . Notice that, since any two rectifiable Cantor sets in \mathbb{R}^3 are equivalently embedded (because both can be sent into a straight line, and they are certainly equivalently embedded there by a homeomorphism that can evidently be extended to all of \mathbb{R}^3), all the T_i but at most one are non rectifiable. Discarding the latter we may assume without loss of generality that all the T_i are non rectifiable.

For each T_i follow the construction of Section 1 to obtain a nonattracting 2–sphere S_i , but now using Fox–Artin feelers as described above. This guarantees that the set W_i of wild points of S_i is precisely T_i (Remark 25). Since the T_i are not rectifiable, an application of Theorem 2 shows that no S_i can be an attractor.

Now suppose that there exists an ambient homeomorphism h that sends S_i onto S_j , with $i \neq j$. It follows immediately from the definition of local flatness that if S_i is locally flat at p then S_j is locally flat at $h(p)$ and conversely or, equivalently stated in terms of wild points, $h(W_i) = W_j$. However, the surfaces were constructed in such a way that $W_i = T_i$ and $W_j = T_j$, so we would have a homeomorphism of \mathbb{R}^3 that sends T_i onto T_j , thus contradicting the fact that the T_i are all inequivalently embedded. \square

Remark 26. Garity, Repovš and Željko [12, Theorem 2, p. 294] strengthened the result of Sher by showing that there exists an uncountable family of Cantor sets $\{T_i : i \in I\}$ that, in addition to being inequivalently embedded, are all homogeneous. Using this and the argument sketched earlier that the homogeneity of T_i is enough to guarantee that $W_i = T_i$ it is possible to give an alternative, shorter proof of Corollary 3. We prefer the approach taken above because it avoids the homogeneity condition which, as we have seen, is not essential for the validity of Corollary 3.

7. CONCLUDING REMARKS AND OPEN QUESTIONS

In this last section we include some remarks and questions that are prompted by the results obtained in this paper. In addition to properties (P1) to (P5) of r already introduced in Section 3 we shall also make use of the following ones:

- (P6) If two compact sets $K_1, K_2 \subseteq \mathbb{S}^3$ have homeomorphic complements, then $r(K_1) = r(K_2)$.
- (P7) If S is a connected surface in \mathbb{S}^3 and U_1, U_2 denote its two complementary domains in \mathbb{S}^3 , then $r(S) = r(\bar{U}_1) + r(\bar{U}_2)$.
- (P8) For every K the inequality $\beta_1(K) \leq r(K)$ holds. If K is a polyhedron, then $\beta_1(K) = r(K)$. The same holds true when K is tame, because of the invariance property of r .

(These are Theorem 15, p. 3600; Proposition 39, p. 3619; Theorem 42 and Proposition 44, p. 3620ff., respectively, from [25]). Here $\beta_i(K)$ denotes the i th Betti number $\beta_i(K) := \text{rk } \check{H}^i(K; \mathbb{Z}_2)$. Since we will always use \mathbb{Z}_2 coefficients we will suppress them from the notation and switch freely between homology and cohomology as convenient.

7.1. We begin with a word of caution about the adequacy of $r(K)$ as an indicator of tameness. For simplicity let us restrict ourselves to the case of a 2–sphere $S \subseteq \mathbb{R}^3$. If S is tame then $r(S) = \beta_1(S) = 0$ according to (P8). But does the equality $r(S) = 0$ *characterize* tame spheres? Consider the following two examples:

(i) Suppose that S is locally tame except at a single point and denote by U_1 and U_2 the two complementary domains of S in \mathbb{S}^3 . A result of Cantrell [6, Theorem 1, p. 250] implies that both U_1 and U_2 are open 3–cells. Consequently $\mathbb{S}^3 - S$ is homeomorphic to $\mathbb{S}^3 - \mathbb{S}^2$ and so by property (P6) of r we conclude that $r(S) = r(\mathbb{S}^2) = 0$.

(ii) Gillman [13, Theorem 5, p. 253] constructs a 2–sphere $S \subseteq \mathbb{R}^3$ such that every point of S is wild and both complementary domains of S in \mathbb{S}^3 are open 3–cells. The same argument as before then implies that $r(S) = 0$.

These two examples illustrate that one may well have $r(S) = 0$ for wild spheres S ; even for spheres that are everywhere wild. By contrast, the wild sphere of Antoine has only a Cantor set of wild points but nevertheless has $r = \infty$, so r is not even “monotonically increasing with the amount of wildness” as one may have hoped for. We may conclude, at least heuristically, that r does not generally perform well as a measure of wildness.

A beautiful result of Bing can be used to gain some insight into the facts observed above. We first need the following remark:

Remark 27. If a 2–sphere $S \subseteq \mathbb{R}^3$ has $r(S) = 0$ then for every $\epsilon > 0$ there exist 2–spheres S_1 and S_2 (which can even be taken to be polyhedral) lying on opposite sides of S and contained in an ϵ –neighbourhood of S .

Proof. Consider the two complementary domains U_1 and U_2 of S in \mathbb{S}^3 . The equality $0 = r(S) = r(\bar{U}_1) + r(\bar{U}_2)$ given by (P7) implies that $r(\bar{U}_1) = r(\bar{U}_2) = 0$. Also, by Alexander duality

$$\check{H}^2(\bar{U}_1) = \check{H}_0(\mathbb{S}^3 - \bar{U}_1) = \check{H}_0(U_2) = 0$$

and similarly for \bar{U}_2 . By the nullity property (P4) of r we conclude that both \bar{U}_i are cellular; that is, both have a neighbourhood basis comprised of (polyhedral) 3–cells. Hence for $i = 1, 2$ we can find 3–cells B_i containing \bar{U}_i and contained in an ϵ –neighbourhood of \bar{U}_i , and evidently their boundaries $S_1 = \partial B_1$ and $S_2 = \partial B_2$ are (polyhedral) 2–spheres satisfying the required conditions. \square

Following Bing [2], for any two subsets $A, B \subseteq \mathbb{R}^3$ we write $H(A, B) \leq \epsilon$ if there exists a homeomorphism $h : A \rightarrow B$ that moves points no more than ϵ ; that is, $\text{dist}(h(x), x) \leq \epsilon$ for every $x \in A$ (notice that h is not an ambient homeomorphism). Consider the following result [2, Theorem 2.2, p. 109]:

Theorem. (Bing) A 2–sphere $S \subseteq \mathbb{R}^3$ is tame if, and only if, for every $\epsilon > 0$ there exist spheres S_1 and S_2 on opposite sides of S and such that $H(S, S_1) \leq \epsilon$ and $H(S, S_2) \leq \epsilon$.

It is now clear why $r(S) = 0$ is too coarse a condition to guarantee that S is tame: although (by Remark 27) it does imply the existence of spheres S_1 and S_2 on opposite sides of S that are *metrically close* to S , in the sense that they are contained in any prescribed ϵ –neighbourhood of S , there is no control on whether the S_i are also *homeomorphically close* to S , in the sense that $H(S, S_1) \leq \epsilon$ and $H(S, S_2) \leq \epsilon$, but according to the theorem of Bing it is *only* this last condition what guarantees that S is tame.

7.2. Trying to understand how an attractor sits in phase space may seem initially as a problem of mainly topological interest, but it also has dynamical implications because the way an attractor lies in phase space places constraints on the dynamics on the attractor and its region of attraction. Let us illustrate this with a couple of examples.

First consider a surface S that is invariant under an ambient homeomorphism f . Arguing as in the last paragraph of the proof of Corollary 3 we see that the set W of wild points of S is also invariant under f . In particular, if S is minimal then either $W = \emptyset$ (that is, S is tame) or $W = S$ (that is, S is everywhere wild). This is the case, for instance, of an attracting 2–torus S that carries a quasiperiodic motion (a common case when these attractors exist).

For our next example we need to recall a definition. Given a point p in phase space, its *prolongational limit set* $J^+(p)$ is the set of all points q for which there exist sequences $(p_n) \rightarrow p$ and $(t_n) \rightarrow +\infty$ such that $(p_n \cdot t_n) \rightarrow q$. Here time is either discrete or continuous and $p_n \cdot t_n$ denotes the position occupied by p_n at time t_n . For a stable attractor K and any point p of its region of attraction one has that $J^+(p)$ is an invariant nonempty continuum contained in K . The contrapositive of [24, Proposition 49, p. 6181] states that if a wild closed surface S is an attractor for a flow, then there exists a point p in the basin of attraction of S such that the prolongational set $J^+(p)$ is a nondegenerate continuum. Intuitively, this means that the future trajectory of any neighbourhood of p is asymptotically

“smeared out” over an extended region of the attractor, as opposed to shrunk down and carried to a definite point in the attractor. Thus the wildness condition on S has consequences on how the trajectories of the dynamical system approach the attractor.

The flavour of the result just mentioned together with the considerations of Subsection 7.1 suggest the following heuristic picture. Let a 2–sphere $S \subseteq \mathbb{R}^3$ be an attractor for a homeomorphism f . Assume that S is wild but nevertheless has $r(S) = 0$. By Remark 27 it is possible to find two spheres S_1 and S_2 contained in the basin of attraction of S and lying on opposite sides of it. Letting them evolve under the dynamics, the S_i will transform into spheres $S_i \cdot k = f^k(S_i)$ still lying on opposite sides of S and getting increasingly closer to it. In general the original spheres S_i will be greatly stretched and deformed as $k \rightarrow \infty$, so even if we chose the initial S_i to be homeomorphically close to S , their transformed $S_i \cdot k$ do not need to be homeomorphically close to S any more. In fact, because of the result of Bing stated above and our assumption that S is wild, we know that the latter has to be the case regardless of the particular details of the homeomorphism f . This picture is only intuitive but, since some of the ideas it involves have formal counterparts in the realm of dynamics (for instance, the amount of stretching of the spheres S_i may be related to the Lyapunov exponents of $f|_S$), one may ask the following rather vague question:

Question 1. Let the 2–sphere $S \subseteq \mathbb{R}^3$ be an attractor for a homeomorphism f . Suppose S is wild but, nevertheless, has $r(S) = 0$. What are the consequences of these assumptions for the dynamics of f ?

7.3. Now we turn our attention to Theorem 17, because it is the one that effects the crucial transition from a global property of S (namely, that $r(S) < \infty$ because S is an attractor) to a local property that involves only a *subset* T of S (namely, that $r(T) < \infty$ too). We begin by casting it into a form that is more inspiring for our present purposes:

Theorem 17’. *If $S \subseteq \mathbb{R}^3$ is a closed connected surface that bounds a 3–manifold and is locally flat outside a totally disconnected set T , then $r(S) \geq r(T)$.*

Proof. Let U_1 and U_2 denote the two complementary domains of S in \mathbb{S}^3 . By assumption S bounds a 3–manifold, so that either \bar{U}_1 or \bar{U}_2 is a compact 3–manifold B ; say it is \bar{U}_1 . Using (P7) and Theorem 17 we have $r(S) = r(\bar{U}_1) + r(\bar{U}_2) = r(B) + r(\bar{U}_2) \geq r(B) \geq r(T)$. \square

Even though this form of the theorem is weaker than the original one, it is still good enough for the dynamical application in this paper: for an attracting surface we obtain $r(T) \leq r(S) < \infty$, so T must be rectifiable.

Revisiting the proof of Theorem 17 given in Section 5 one sees that the assumption that T is totally disconnected is only used at the beginning of Stage 3 to choose a neighbourhood basis $E^{(1)}, E^{(2)}, \dots$ of T in ∂B (which is S in our present formulation) such that: (i) each $E^{(k)}$ is a finite union of disks $E_1^{(k)}, E_2^{(k)}, \dots, E_{n_k}^{(k)}$ and (ii) the basis is decreasing; that is, $E^{(k+1)} \subseteq \text{int } E^{(k)}$ for every k . However, the existence of such a neighbourhood basis is guaranteed not only for a totally disconnected set T but, more generally, for any proper compact subset T of S satisfying $H^1(T; \mathbb{Z}_2) = 0$. Admitting this fact (the proof is not difficult, but it is somewhat long so we cannot include it here) we obtain the following generalization of Theorem 17’:

Theorem 17''. *Let $S \subseteq \mathbb{R}^3$ be a closed connected surface that bounds a 3-manifold. Suppose that S contains a compact subset T such that $\check{H}^1(T; \mathbb{Z}_2) = 0$ and S is locally flat outside T . Then $r(S) \geq r(T)$.*

Continuing this line of thought, one may ask the following question:

Question 2. Is it possible to obtain “local to global” theorems for families of sets S and T other than those of Theorem 17''?

In a previous paper [25, Theorem 41, p. 3620] it was proved that the sphere of Alexander shown in Figure 3 also has infinite r . Unlike the surfaces considered in this paper, its set of wild points is a rectifiable Cantor set and the reason that r ends up being infinite in this case is that the “tentacles” that emanate from the sphere are entangled, even though the Cantor set of wild points itself is not. One may then ask:

Question 3. Suppose $S \subseteq \mathbb{R}^3$ is a surface having a totally disconnected set of wild points W . Is it meaningful to isolate the contributions to $r(S)$ due to the entanglement of the surface near W (à la Alexander) and the wildness of W itself (à la Antoine) as measured by $r(W)$? Is there a lower bound on $r(S)$ similar to that of Theorem 17'' that takes both contributions into account?

7.4. Since $r(K) = \beta_1(K)$ when K is a polyhedron, relations valid for Betti numbers suggest relations that may be true, under suitable hypotheses, for r numbers. Let the compact set K be the union of two compacta K_0 and K_1 . Looking at the the Mayer–Vietoris sequence

$$\dots \longleftarrow \check{H}^1(K_0 \cap K_1) \longleftarrow \check{H}^1(K_0) \oplus \check{H}^1(K_1) \longleftarrow \check{H}^1(K) \longleftarrow \check{H}^0(K_0 \cap K_1) \longleftarrow \dots$$

we see that, if $\check{H}^1(K_0 \cap K_1) = 0$, the middle arrow is a surjection and therefore $\beta_1(K) \geq \beta_1(K_0) + \beta_1(K_1)$. The subadditivity property states that the corresponding inequality for r numbers is true under the additional assumption that the decomposition $K = K_0 \cup K_1$ be tame. If we do not require $\check{H}^1(K_0 \cap K_1)$ to be zero then the Mayer–Vietoris sequence yields then inequality $\beta_1(K) + \beta_1(K_0 \cap K_1) \geq \beta_1(K_0) + \beta_1(K_1)$, which involves the extra term $\beta_1(K_0 \cap K_1)$. Heuristically it then seems reasonable to ask the following:

Question 4. Let $K = K_0 \cup K_1$ be a tame decomposition. Does the inequality

$$(6) \quad r(K) + r(K_0 \cap K_1) \geq r(K_0) + r(K_1)$$

hold? (Maybe under some additional hypothesis concerning the decomposition $K = K_0 \cup K_1$).

7.5. Our interest in the generalized subadditivity property is motivated both by curiosity and also because it would allow us to obtain a neat generalization of Theorem 17'' with a relatively small effort:

Theorem 28. *Assume that a suitable form of the generalized subadditivity property (6) is true. Let $S \subseteq \mathbb{R}^3$ be a closed connected surface and let T be a compact subset of S such that S is locally flat outside T . Then*

$$r(S) + \beta_0(S - T) \geq r(T).$$

[Notice that two of the hypotheses of Theorem 17' have been removed: S is not required to bound a 3-manifold anymore and no condition is placed on $\check{H}^1(T; \mathbb{Z}_2)$.]

$\beta_0(S - T)$ is precisely the number of connected components into which T separates the surface S , and for the above inequality to be informative we need it to be finite. When T is totally disconnected this is certainly the case because $S - T$ is connected, and the above reads $r(S) + 1 \geq r(T)$. This is slightly weaker than the conclusion $r(S) \geq r(T)$ of Theorem 17', but still good enough to prove Theorem 2 (using the same argument).

Proof of Theorem 28. Let N be a neighbourhood of T in S that is a compact 2-manifold with boundary (any compact subset of a surface has a basis of neighbourhoods like these). Consider the decomposition of S into the two compact sets $K_0 := S - \text{int } N$ and $K_1 := N$. Their intersection is ∂N , which is contained in the locally flat part of S . Since S is bicollared there, each component of ∂N (which is a simple closed curve) can be extruded to a tame annulus “transverse” to S , and the union of these separates K_0 and K_1 in the fashion of a tame decomposition. Therefore, assuming a suitable form of generalized subadditivity holds, $r(S) + r(\partial N) \geq r(S - \text{int } N) + r(N)$. Furthermore, since $S - \text{int } N$ and ∂N are contained in the locally flat part of S , it is easy to show that $r(S - \text{int } N) = \beta_1(S - \text{int } N)$ and $r(\partial N) = \beta_1(\partial N)$. Substituting in the generalized subadditivity inequality we get

$$(7) \quad r(S) \geq \beta_1(S - \text{int } N) - \beta_1(\partial N) + r(N).$$

Consider the following portion of the long exact sequence in homology for the pair $(S - \text{int } N, \partial N)$:

$$\dots \longrightarrow H_2(S - \text{int } N) \longrightarrow H_2(S - \text{int } N, \partial N) \xrightarrow{\delta} H_1(\partial N) \longrightarrow H_1(S - \text{int } N) \longrightarrow \dots$$

Observe that $S - \text{int } N$ is a compact 2-manifold each of whose connected components has at least one boundary component. Therefore $H_2(S - \text{int } N) = 0$, so the arrow labeled δ in the exact sequence above is injective. This implies that $\beta_1(\partial N) - \beta_2(S - \text{int } N, \partial N) \leq \beta_1(S - \text{int } N)$, and substituting in (7) yields $r(S) \geq -\beta_2(S - \text{int } N, \partial N) + r(N)$. Finally, using excision and Alexander duality there are isomorphisms $H_*(S - \text{int } N, \partial N) = H_*(S, N) = H_{2-*}(S - N)$, so we can rewrite our inequality as

$$r(S) \geq -\beta_0(S - N) + r(N).$$

One can always choose N in such a way that different components of $S - N$ lie in different components of $S - T$ (see the proof of the frame theorem [19, Theorem 6, p. 72]), so that $\beta_0(S - N) \leq \beta_0(S - T)$. For this choice of N , then,

$$r(S) \geq -\beta_0(S - N) + r(N) \geq -\beta_0(S - T) + r(N).$$

Letting these N run in a neighbourhood basis (N_k) of T and taking the limit inferior as $k \rightarrow \infty$ we conclude that

$$r(S) + \beta_0(S - T) \geq \liminf_{k \rightarrow \infty} r(N_k) \geq r(T),$$

where the last inequality follows from the semicontinuity property of r . □

REFERENCES

- [1] L. Antoine. Sur l'homomorphie de figures et de leurs voisinages. *J. Math. Pures Appl.*, 86:211–325, 1921.
- [2] R. H. Bing. Conditions under which a surface in E^3 is tame. *Fund. Math.*, 47:105–139, 1959.
- [3] R. H. Bing. Tame Cantor sets in E^3 . *Pacific J. Math*, 11:435–446, 1961.
- [4] M. Brown. A proof of the generalized Schoenflies theorem. *Bull. Amer. Math. Soc.*, 66:74–76, 1960.
- [5] M. Brown. Locally flat imbeddings of topological manifolds. *Ann. Math.*, 75(2):331–341, 1962.
- [6] J. C. Cantrell. Almost locally polyhedral 2–spheres in \mathbb{S}^3 . *Duke Math. J.*, 30:249–252, 1963.
- [7] S. Crovisier and M. Rams. IFS attractors and Cantor sets. *Topology Appl.*, 153:1849–1859, 2006.
- [8] R. J. Daverman and G. A. Venema. *Embeddings in manifolds*. American Mathematical Society, 2009.
- [9] P. F. Duvall and L. S. Husch. Attractors of iterated function systems. *Proc. Amer. Math. Soc.*, 116:279–284, 1992.
- [10] R. H. Fox and E. Artin. Some wild cells and spheres in three-dimensional space. *Ann. Math. (2)*, 49(4):979–990, 1948.
- [11] B. M. Garay. Strong cellularity and global asymptotic stability. *Fund. Math.*, 138:147–154, 1991.
- [12] D. Garity, D. Repovš, and M. Željko. Uncountably many inequivalent Lipschitz homogeneous Cantor sets in \mathbb{R}^3 . *Pacific J. Math.*, 222(2):287–299, 2005.
- [13] D. S. Gillman. Note concerning a wild sphere of Bing. *Duke Math. J.*, 31(2):247–254, 1964.
- [14] B. Günther. A compactum that cannot be an attractor of a self-map on a manifold. *Proc. Amer. Math. Soc.*, 120(2):653–655, 1994.
- [15] B. Günther and J. Segal. Every attractor of a flow on a manifold has the shape of a finite polyhedron. *Proc. Amer. Math. Soc.*, 119(1):321–329, 1993.
- [16] V. Jiménez and J. Llibre. A topological characterization of the ω –limit sets for analytic flows on the plane, the sphere and the projective plane. *Adv. Math.*, 216:677–710, 2007.
- [17] V. Jiménez and D. Peralta-Salas. Global attractors of analytic plane flows. *Ergodic Theory Dynam. Systems*, 29:967–981, 2009.
- [18] H. Kato. Attractors in Euclidean spaces and shift maps on polyhedra. *Houston J. Math.*, 24:671–680, 1998.
- [19] E. E. Moise. *Geometric topology in dimensions 2 and 3*. Springer-Verlag, 1977.
- [20] J. Munkres. *Elements of algebraic topology*. Addison–Wesley Publishing Company, Inc., 1984.
- [21] R. Ortega and J. J. Sánchez-Gabites. A homotopical property of attractors. *Topol. Methods Nonlinear Anal.*, 46:1089–1106, 2015.
- [22] C. P. Rourke and B. J. Sanderson. *Introduction to piecewise-linear topology*. Ergebnisse der Mathematik und ihrer Grenzgebiete, Band 69. Springer-Verlag, 1972.
- [23] J. J. Sánchez-Gabites. On the shape of attractors for discrete dynamical systems. Submitted. Provisionally available at <http://arxiv.org/abs/1511.06549>.
- [24] J. J. Sánchez-Gabites. How strange can an attractor for a dynamical system in a 3–manifold look? *Nonlinear Anal.*, 74:6162–6185, 2011.
- [25] J. J. Sánchez-Gabites. Arcs, balls and spheres that cannot be attractors in \mathbb{R}^3 . *Trans. Amer. Math. Soc.*, 368(5):3591–3627, 2016.
- [26] J. M. R. Sanjurjo. Multihomotopy, Čech spaces of loops and shape groups. *Proc. London Math. Soc. (3)*, 69(2):330–344, 1994.
- [27] R. B. Sher. Concerning wild Cantor sets in E^3 . *Proc. Amer. Math. Soc.*, 19:11951200, 1968.

FACULTAD DE CIENCIAS ECONÓMICAS Y EMPRESARIALES. UNIVERSIDAD AUTÓNOMA DE MADRID, CAMPUS UNIVERSITARIO DE CANTOBLANCO. 28049 MADRID (ESPAÑA)

E-mail address: JaimeJ.Sanchez@uam.es