

Relationship between ambidexterity and entrepreneurial intensity

María-Soledad Castaño-Martínez^a, Miguel-Ángel Galindo-Martín^b, María-Teresa Méndez-Picazo^c and Daniel Palacios-Marqués^d

^aUniversity of Castilla-La Mancha, Albacete, Spain; ^bUniversity of Castilla-La Mancha, Ciudad Real, Spain; ^cUniversity Complutense of Madrid, Madrid, Spain; ^dUniversitat Politècnica de València, Valencia, Spain

ABSTRACT

Within organisational analysis, a concept that has been gaining importance has been organisational ambidexterity, where two factors play an important role: entrepreneurial intensity and innovations. The objective of this article is to analyse the relationship between entrepreneurial intensity and ambidexterity. The conceptualisation of ambidexterity distinguishes between ambidextrous activities and ambidextrous outcomes. To carry out this objective, we have tested several theoretical relationships. We have used partial least squares methodology to develop an empirical study in 25 European countries. Results confirm that collaboration networks have a positive effect on entrepreneurship intensity. This effect is greater than the one obtained by ambidextrous activities or new technologies. We also show that entrepreneurship intensity has a mediating role between ambidextrous activities and ambidextrous outcomes.

ARTICLE HISTORY

Received 9 July 2018
Accepted 22 January 2019

KEYWORDS

Entrepreneurial intensity; ambidextrous activities; ambidextrous outcomes; innovation

JEL CLASSIFICATIONS

L26; L25; O31

1. Introduction

In a dynamic and competitive business context, firms have to understand and respond to the changing needs of their customers. Within organisational analysis, organisational ambidexterity is a concept that has been gaining importance. Tushman and O'Reilly (1996, p. 24) define organisational ambidexterity as the 'ability to simultaneously pursue both incremental and discontinuous innovation... from hosting multiple contradictory structures, processes, and cultures within the same firm' (quoted in O'Reilly & Tushman, 2013, p. 324). In this sense, it has been argued that engaging in both incremental and discontinuous processes is crucial for the long-term survival and success of organisations (Gibson & Birkinshaw, 2004).

It is considered that the main differences between the different definitions of the organisational ambidexterity concept are due to the fact that they concern the

CONTACT Daniel Palacios-Marqués  dapamar@doe.upv.es

© 2019 The Author(s). Published by Informa UK Limited, trading as Taylor & Francis Group.

This is an Open Access article distributed under the terms of the Creative Commons Attribution License (<http://creativecommons.org/licenses/by/4.0/>), which permits unrestricted use, distribution, and reproduction in any medium, provided the original work is properly cited.

achievement of an optimal balance between exploration and exploitation or whether they present a combination of high levels of exploration and exploitation (Cao, Gedajlovic, & Zhan, 2009; Simsek, Heavey, Veiga, & Souder, 2009). In this line, according to March (1991), ambidexterity refers to the ability of an organisation to simultaneously combine its existing capabilities and explore new ones. Considering this perspective, an important strand of literature has emerged focussing on the relevance of the role of human resources and organisational factors on the development of ambidexterity (Ahammad, Lee, Malul, & Shoham, 2015; Gibson & Birkinshaw, 2004; Heavey & Simsek, 2017; Koryak, Lockett, Hayton, Nicolaou, & Mole, 2018; Meglio, King, & Risberg, 2015; Patel, Messersmith, & Lepak, 2013; Roldán-Bravo, Ruiz-Moreno, & Lloréns-Montes, 2018). From this perspective, the main challenge is that the research is fragmented and there is a lack of a unifying framework.

Therefore, considering the different perspectives, we find that ambidexterity refers to the existence of multiple contradictory structures, processes and cultures, some of which are optimised through innovation. From this perspective, we find that two factors have to be taken into account in the analysis: the role played by the entrepreneur and innovations. The traditional literature on ambidexterity usually does not contemplate the first aspect, the entrepreneur, despite its importance as a driver of innovation (Brem, 2017; Galindo & Méndez, 2014; Martínez-Conesa, Soto-Acosta, & Carayannis, 2017; Onyema, 2016; Palacios-Marqués, Popa, & Alguacil-Mari, 2016; Patel et al., 2013).

The traditional literature has centred on analysing the behaviour of entrepreneurs as agents who make decisions when conducting business (Cassis & Papelalis, 2005; Mathews, 2017; Phelan, Dalgic, Li, & Sethi, 2006), as well as on the factors that may favour entrepreneurship and its effects on different economic objectives (Galindo & Méndez, 2014). Entrepreneurship concerns more than merely the creation of businesses; in other words, it entails not only the factors that favour business creation, but also the behaviour of existing businesses already in existence (Dai, Du, Byun, & Zhu, 2017; Lyon, Lumpkin, & Dess, 2000).

From this perspective, the concept of entrepreneurial intensity has gained importance. Entrepreneurial intensity is defined as the combination of the frequency with which entrepreneurial acts are undertaken and the degree of entrepreneurship, which is determined by three dimensions: innovation, risk taking and proactivity (Morris & Sexton, 1996). As both individuals and organisations can perform entrepreneurial acts, different terms have emerged for the entrepreneurship performed by businesses (Stevenson & Jarillo, 1990). Thus, the term 'corporate entrepreneurship' refers to the entrepreneurial acts that are carried out by existing companies (Burgelman, 1983; Zahra, 1993). Consequently, aspects related to the recognition of opportunities, risk taking and the tenacity to implement innovative ideas despite obstacles are characteristics of entrepreneurial behaviour that are becoming increasingly relevant within the world of organisations. In this line, other authors, such as Antoncic and Hisrich (2001) and Pinchot (1985), use the terms 'intrapreneuring' (Schollhammer, 1982; Vesper, 1984) and 'internal corporate entrepreneurship' (Jones & Butler, 1992). Finally, the term 'corporate entrepreneurial intensity' refers to the frequency with which and degree to which entrepreneurial acts are performed in organisations (Scheepers, Hough, & Bloom, 2013).

Factors that determine intensity are entrepreneurial innovation and the ability of entrepreneurs to take risks and act proactively to take advantage of business opportunities. On the one hand, innovation implies, among other things, allowing entrepreneurial activity to expand, facilitating introduction into new markets, and thus enhancing the competitiveness of the product. On the other hand, the internationalisation of activities has important effects on an organisation's growth rate (Krauss, Frese, Friedrich, & Unger, 2005; Lumpkin & Dess, 1996; Morris & Kuratko, 2002; Zahra & Covin, 1995). Therefore, the behaviour of these factors indicates the volume of entrepreneurial intensity, implying the existence of a greater number of entrepreneurial acts, thereby generating beneficial effects on different economic objectives, such as economic growth and employment policy (Galindo & Méndez, 2014; Krauss et al., 2005; Lumpkin & Dess, 1996; Schumpeter, 1934).

Thus, it is important to include entrepreneurial intensity within ambidexterity analysis. However, to carry out this research, ambidexterity must be contemplated from two perspectives. The first corresponds to activities carried out by the entrepreneur in the exploration process, that is, acquisition and pursuit of new knowledge – what Laukkanen (2012) calls 'ambidextrous activities'. The second concerns the outcome of an entrepreneur performing ambidextrous activities – what Laukkanen (2012) calls 'ambidextrous outcomes'.

The objective of this study is to analyse the relationship between entrepreneurial intensity and ambidexterity, distinguishing between ambidextrous activities and ambidextrous outcomes. Thus, in the literature review, the essential elements of ambidexterity and entrepreneurial intensity are revealed. The section also lays out the relationship between the two types of ambidexterity (ambidextrous activities and ambidextrous outcomes) and entrepreneurial intensity. In the methodology section, using a partial least squares (P.L.S.) estimation carried out in 25 European countries, we compare the hypotheses of the research. The final section concludes.

2. Literature review

In accordance with the conceptualisation of ambidexterity, it is necessary to verify the relevance of both innovations and entrepreneurs when analysing this variable. Before moving to the specifics of entrepreneurial intensity, we must first specify the aspects related to ambidexterity.

The first aspect to consider is that the entrepreneur has to face a competitive environment with, among other characteristics, risk, which involves carrying out task exploration through the acquisition and pursuit of new knowledge. Laukkanen (2012) calls this 'ambidextrous activities'. Thus, the entrepreneur's knowledge is acquired and expanded to introduce those new processes and innovations that enable improvement of the business. In this sense, experimenting and transforming are carried out by assuming changes in the structure of the company (Simsek et al., 2009).

What is concretely referred to as entrepreneurial intensity is the combination of the frequency with which entrepreneurial acts are undertaken and the degree of entrepreneurship, which is determined by three dimensions: innovation, risk taking and proactivity (Morris & Sexton, 1996). The concept of the degree of

entrepreneurship was introduced by Cooper and Dunkelberg (1986) in order to analyse the different ways of becoming a business owner and assuming different levels of entrepreneurial intensity.

The three dimensions mentioned that determine the degree of entrepreneurship are innovativeness, risk taking and proactiveness (Covin & Slevin, 1989; Ginsberg, 1985; Miles & Arnold, 1991; Miller, 1983; Morris & Paul, 1987). The first of these, innovativeness, refers to the search for new and creative ways to solve problems or meet needs (Kyoon, 2014). The second, risk taking, is the disposition to commit resources to business opportunities assuming the possibility of failure. The third, proactiveness, is the will to carry out entrepreneurial activity despite obstacles.

Focussing on the aspect of innovation as one of the factors that affect entrepreneurial intensity, Schumpeter (1934) considers innovation as a relevant variable for analysis of entrepreneurial behaviour. He considers the introduction of new products or changes in existing products, new processes of production or organisational management and the opening of new markets or the use of new sources of supply (Gartner, 1985; Vesper, 1984). More recently, Zortea-Johnston, Darroch, and Matear (2012) show that companies targeting markets introduce innovations to cover the needs of current and future customers to alter the market structure, which can yield better results for these firms. In this line, Miller (1983) states that entrepreneurial organisations are those involved in innovating in the market in which they operate and that take risks and persist in innovating ahead of their competitors. Within the organisation, these new ideas could give way to new processes, products, services or businesses (Lyon et al., 2000). Thus, creativity leads to innovation and the intrapreneur leads this process (Kuratko & Morris, 2018; Morris & Kuratko, 2002).

Focusing on the objectives of organisations and their manner of innovating, Drucker (1954) states that organisations act with the aim of capturing and conserving clients, which is the only valid purpose of a business. Zortea-Johnston et al. (2012) argue that client-focussed organisations are more likely to develop innovations driven by the market, since they prioritise the needs of their clients when introducing new products. The type of business influences innovation and the business innovation model identifies itself as the authentic differential factor at the time of conceiving and introducing novelties in the market (Johnson, Christensen, & Kagermann, 2008; Zortea-Johnston et al., 2012). Therefore, we propose the following relationship:

Hypothesis 1. Ambidextrous activities have a positive relationship on entrepreneurship intensity.

Within the factors that would influence the three dimensions that comprise intensity entrepreneurship, we highlight the use of new technologies. For innovation to emerge from companies, it is necessary that they have highly qualified staff who are proactive at cooperating and innovating, as well as the appropriate technology (modern manufacturing facilities, updated technologies, process technologies developed internally, and proprietary product technologies) (Lawson & Samson, 2001; Rothaermel & Hess, 2007; Zahra & Nielsen, 2002).

The way entrepreneurs recognise opportunities for business creation is one of the first critical abilities in the first stages. In this sense, information systems are very useful for filtering business models with outstanding results. When we assume that

technology is at the core and origin of the new venture, we refer to technology based-entrepreneurship. If technology is involved, entrepreneurship consists of bringing important changes into traditional markets (Phene, Tallman, & Almeida, 2012; Soto-Acosta & Meroño-Cerdan, 2008).

The use of new technologies critically determines the extent to which a firm can be called innovative (Palacios-Marqués et al., 2016; Scheepers et al., 2013). We posit that the entrepreneur has to introduce new and innovative products and services using new technologies in an innovative way. We hypothesise as follows:

Hypothesis 2. The use of new technologies positively affects entrepreneurship intensity.

The entrepreneur's social networks and how they enable advancement in economic activities in a complex economic system are another factor to keep in mind (Cassis & Papelasis, 2005; Castaño-Martínez, Ruiz-Fuentsanta, & Martínez-Rodríguez, 2013; Palacios-Marqués et al., 2016; Swedberg, 2000). These social networks provide various benefits to the entrepreneur, such as favouring innovation and the perception and recognition of opportunities (Dakhli & De Clercq, 2004; Kaasa, 2009; Onyema, 2016; Subramaniam & Youndt, 2005); the creation of intellectual capital and organisational learning (Hitt, Lee, & Yucel, 2002); greater ability to acquire relevant knowledge and capacities (Nahapiet & Ghoshal, 1998); access to exchange of resources (Tsai & Ghoshal, 1998); provision of relevant information (Fukuyama, 2000); increment entrepreneurial performance (De Carolis & Saporito, 2006; Liao & Welsch, 2003; Nahapiet & Ghoshal, 1998); and enabling entry to international markets (Phelan et al., 2006). Other authors allude to the role of business networks in the transfer of technology, the importance of establishing partnerships and research contracts, and the repercussion of the relationships with suppliers and clients in the innovative process (Pittiglio, Sica, & Villa, 2009).

Thus, this configuration of networks facilitates the necessary and sufficient conditions for transferring information and resources that favour entrepreneurial success. Moreover, these networks develop synergies that give rise to creative ideas and combinations (Subramaniam & Youndt, 2005). The success or failure of the entrepreneurial actions of consolidated companies through the introduction of innovations in the market often depends on changes in their environment and the innovation of other companies. Thus, the company is immersed in an ecosystem of interdependent innovations (Adner & Kapoor, 2010; Martínez-Conesa et al., 2017). Collaboration between companies to achieve product innovations could lead to new customer acquisitions and the improvement of efficiency (Davis & Eisenhardt, 2011; Gulati & Sytch, 2007).

In general, when entrepreneurs belong to a network and decide to work together, it has a positive impact on entrepreneurial intensity, (Dakhli & De Clercq, 2004; Kaasa, 2009; Phelan et al., 2006; Pittiglio et al., 2009; Subramaniam & Youndt, 2005). Meanwhile, social networks play an essential role in the internationalisation process of companies, owing to the need for entrepreneurs to create networks of commitment and trust prior to internationalisation, which allows them to obtain relevant information of these new markets, ensuring the success of the process (Johanson & Vahlne, 2009; Cesinger et al., 2016). This theoretical relationship leads us to formulate the following hypothesis:

Hypothesis 3. Collaboration networks among entrepreneurs have a positive relationship with entrepreneurial intensity.

The second type of ambidexterity considered by Laukkanen (2012) is ambidextrous outcomes, which are the consequence of the entrepreneur carrying out ambidextrous activities. One way to consider the outcomes obtained when the entrepreneur applies his or her capabilities and competences in the production process is to include as indicators of the ambidextrous outcome construct the patents for applications and industrial applications, as well as trademark applications. As indicated, the skills acquired by the entrepreneur that enable the development of ambidextrous activities lead to the introduction of those innovations and improvements in products that allow the business to be sustainable in the long term.

The innovations carried out by the entrepreneur, which can be of different types (disruptive, radical or incremental), could generate important long-term effects for the company. However, from our viewpoint, we should consider not only innovations but also changes that have been taking place in the products generated by the business, as this is also a means of improvement within the environment in which the business conducts its activity. There is extensive literature relating ambidexterity to innovation (Burgers, Jansen, Van den Bosch, & Volberda, 2009; Carayannis & Campbell, 2006; Phene et al., 2012; Rothaermel & Alexandre, 2009; Sarkees & Hulland, 2009; Soto-Acosta & Meroño-Cerdan, 2008; Tushman, Smith, Wood, Westerman, & O'Reilly, 2010) and the market's valuation of products (Uotila, Maula, Keil, & Zahra, 2009; Wang & Li, 2008). Thus, we hypothesise as follows:

Hypothesis 4. There is a positive relationship between entrepreneurial intensity and ambidextrous outcomes.

3. Empirical analysis

3.1. Methods and data

In order to analyse the theoretical relationships previously exposed, an exploratory empirical analysis was performed through P.L.S. estimation for 25 European countries¹ in 2012. The estimation was conducted using the P.L.S. method with the SmartPLS 3.2.4 program.

P.L.S. regression is used when there are several explanatory variables or a proxy to an economic occurrence that is not observed directly; the latent variables synthesise and replace this information (Tenenhaus, 1998). Table 1 contains the definition of each of the indicators that form the different latent variables of the model proposed. The indicators are from the World Development Indicators (World Bank, 2016) and the Global Entrepreneurship Monitor Project (G.E.M.) database (Global Entrepreneurship Monitor Project (GEM), 2016).

P.L.S. was chosen as the estimation method because it allows for more sophisticated multivariate analysis than the traditional methods (Hair, Hult, Ringle, & Sarstedt, 2016). Furthermore, its use is recommended in the following cases (Bacon, 1999; Wong, 2013): small sample size; little available theory for applications; paramount predictive accuracy; and inability to ensure the correct model specification.

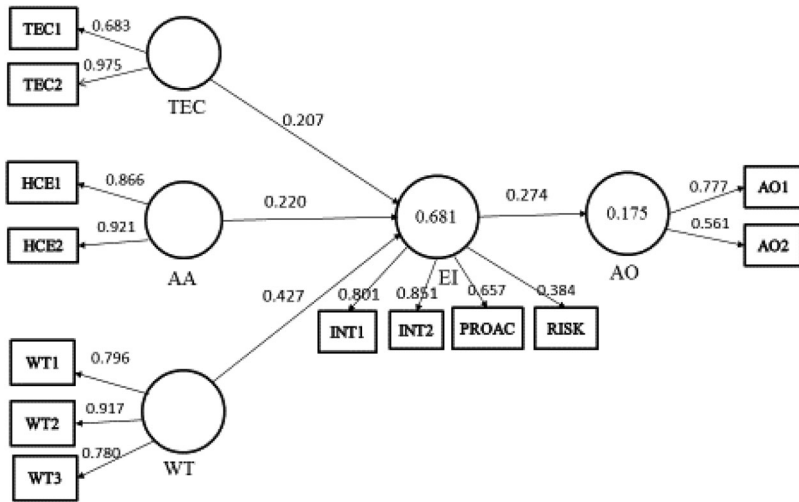

Figure 1. Estimation of the structural equation model. Source: The Authors.

Two models are used in this type of study: a measurement model and a structural model. The first model defines the relationship between observable variables (indicators) and latent variables. The second model measures the relationships between latent variables, indicating which latent variable directly or indirectly influences other latent variables. For the measurement model, we used a factorial analysis, which allowed us to decide which items to use as indicators of each latent variable (factor), as shown in Figure 1. For the structural model, following the theoretical framework set out in the previous section, the confidence factor was regarded as exogenous, as it was liable to affect the other factors (Hair et al., 2016).

3.2. Measurement of variables

To carry out our estimation, we elaborated an entrepreneurial intensity construct, made up of different items taken from the G.E.M. survey (Global Entrepreneurship Monitor Project (GEM), 2016). For this estimation, the items of the G.E.M. survey that correspond to established entrepreneurs were used, that is, those that had been operating a business for more than 42 months.

As shown in the previous section, entrepreneurship activity is determined by three dimensions: innovation, risk taking, and proactivity. Regarding innovation, some literature considers that there is a relationship between innovation and internationalisation, because the innovation process makes it possible to discover new distribution channels in international markets (Frohman, 1983; Kotabe, Srinivasan, & Aulakh, 2002) and internationalisation enables the achievement of the benefits of innovation (Kafourous, Buckley, Sharp, & Wang, 2008; Williams & Shaw, 2011). For this reason, two indicators were introduced as innovation proxies in the entrepreneurship intensity indicator: first, exporting between 75% and 100% of production (INT1) and second, exporting between 25% and 74% of production (INT2). In the case of risk, the indicator supplied by the G.E.M. survey is that fear of failure would prevent starting a business (RISK). To measure entrepreneurs’ proactiveness in leveraging business

Table 1. Constructs and indicators.

Constructs	Indicators
Entrepreneurial intensity (EI)	<ul style="list-style-type: none"> • Exporting between 75% and 100% of its production (INT1) • Exporting between 25% and 74% of its production (INT2) • No: Fear of failure would prevent starting a business (RISK) • Opportunity motive (PROAC)
Technology used (TEC)	<ul style="list-style-type: none"> • Uses very latest technology (only available since last year) (TEC1) • Uses new technology (1–5 years) (TEC2)
Ambidextrous activities (AA)	<ul style="list-style-type: none"> • University degree (HCE1) • Postgraduate degree (HCE2)
Working together with other enterprises (WT)	<ul style="list-style-type: none"> • Working together with others to make your business more effective (WT1) • Working together with other enterprises or organisations to produce goods or services (WT2) • Working together with others to create new products or services to new customers (WT3)
Ambidextrous outcomes (AO)	<ul style="list-style-type: none"> • Patents for applications and industrial applications for residents (AO1) • Trademark applications (AO2)

Source: The Authors.

opportunities, we selected an item from the survey that measures opportunity as the predominant reason that leads to entrepreneurship in a society (opportunity motive). Finally, ambidextrous outcomes include patents for applications and industrial applications for residents (AO1) and trademark applications (AO2).

Regarding ambidexterity, we followed Laukkanen (2012), as indicated in the previous section, with regard to the two types, ambidextrous activities and ambidextrous outcomes. The first type corresponds to the entrepreneur's acquisition and pursuit of new knowledge. In this sense, we assumed that the entrepreneurs must acquire the capabilities and competences to obtain such new knowledge. The common way to obtain it is through a university degree or secondary or tertiary studies (Ambos, Mäkelä, Birkinshaw, & D'Este, 2008; Rezende, Torres, Correia, Nicolini, & Bernardes, 2016). The indicators considered are university degree (HCE1) and postgraduate degree (HCE2), because we assumed that this education would provide the skills and capabilities required to make the right decisions in the exploration process.

In Table 1, we present the indicators used to measure the theoretical constructs.

4. Findings and discussion

In Figure 1, we show the results of the structural model. This figure shows the coefficients of the different paths and the results of the hypotheses proposed.

The measurement model is valued by an item's individual liability, internal consistency, and discriminant validity. The simple relationship between each item and its respective construct is measured by the Cronbach's alpha value (Barclay, Higgins, & Thompson, 1995; Nunnally & Bernstein, 1994). Convergent validity (AVE) reflects the variance extracted from the indicators, including the common variability absorbed

Table 2. Reliability measurements.

	AVE	Cronbach's alpha	Composite reliability	R ²
EI	0.59	0.69	0.80	0.681
AA	0.80	0.75	0.89	
TEC	0.71	0.67	0.83	
WT	0.69	0.78	0.87	
AO	0.62	0.71	0.82	

Source: The Authors.

by the latent variable. A value greater than 0.5 can be accepted as a good measure of fit (Fornell, 1982; Fornell & Larcker, 1981).

Cronbach's alpha indicates the internal coherence of the indicators they form. Values greater than 0.7 indicate the existence of internal coherence. Redundancy measures explain the predictive capacity of the model. Regarding the structural sub-model, it is possible to measure the R² coefficients associated with latent variable regressions only in the endogenous constructs. R² indicates the construct variance explained by the model.

All the endogenous latent variables are significant, with values greater than 0.1 (Falk & Miller, 1992). Obviously, R² coefficients are not high, as we attempted to check some relationships and their value, but we did not consider the total social and economic variables influencing each latent variable measured.

From Table 2, we observe that the reliability and goodness of fit of the model are adequate, because the AVE of all latent variables is greater than 0.5 and the R² model is greater than 0.1. However, regarding the internal coherence of the indicators that form the constructs, it should be noted that the Cronbach's alpha values of some latent variables are slightly under 0.7 (entrepreneurial intention = 0.69 and technology used = 0.67), as shown in Table 2.

Table 3 shows that the cross-loads are always greater for the latent variables on which the respective items are loaded. Cross-loading items represent prime candidates for removal from subsequent analysis, with the goal of improving model fit. Nevertheless, these indicators are well assigned to the latent variables in the estimated model, owing to the fact that they represent the economic point of analysis.

Table 4 shows the matrix of correlations between the latent variables of the proposed model. Traditional models and procedures for analysis of covariance structures are based on the assumption that the sample covariance matrix is under analysis. The results obtained in Table 4 are satisfactory.

Table 5 shows the direct and indirect effects between the latent variables of the study. The relationship between ambidextrous activities, collaboration networks, and new technologies used with ambidextrous outcomes is not direct. Entrepreneurship intensity acts as a mediating variable between three constructs affecting entrepreneurship intensity and ambidextrous outcomes.

Significance cannot be calculated conventionally using P.L.S. and hence, the bootstrapping technique must be used. Bootstrapping analyses the significance of the relationships between variables. Table 6 shows that the relationships are significant at a level of 10%. According to Hair et al. (2016, p. 153) a significance level of 10% is commonly used for exploratory studies.

Table 3. Cross-loads for convergent validity.

	EI	HCE	TECH	WT	AO
AO1	-0.209	0.013	-0.207	-0.084	0.777
AO2	0.159	0.298	-0.371	-0.076	0.561
HCE1	0.208	0.866	-0.197	0.168	0.182
HCE2	0.267	0.921	-0.389	0.315	0.142
INT1	0.801	0.157	0.126	0.354	0.053
INT2	0.851	0.046	0.479	0.509	0.161
PROAC	0.657	0.417	-0.080	0.361	0.360
RISK	0.384	0.161	-0.376	0.019	0.261
TEC1	0.075	-0.251	0.683	0.137	0.003
TEC2	0.247	-0.326	0.975	0.223	-0.075
WT1	0.400	0.062	0.460	0.796	0.075
WT2	0.498	0.359	0.025	0.917	0.174
WT3	0.431	0.249	0.121	0.780	-0.215

Source: The Authors.

On the one hand, the estimation results show that there is a positive effect of ambidextrous activities on entrepreneurial intensity (H1), (0.220 and significant $p \leq 10\%$), which is in accordance with Laukkanen (2012). This result confirms that the improvement of ambidextrous activities is a stimulus for entrepreneurial activity and has a beneficial effect on the creation of new business, patents and market value. On the other hand, there is a positive relationship between the use of new technologies (H2) and entrepreneurial intensity, (0.207 and significant $p \leq 10\%$), which confirms Scheepers et al.'s (2013) approach.

The results support hypothesis H3 (collaboration networks among entrepreneurs have a positive relationship with entrepreneurial intensity). The coefficient of the equation is 0.427 (significant $p \leq 10\%$), which is in accordance with Dakhli and De Clercq's (2004) thesis. This effect is greater than that obtained in H1 and H2, and thus, it is important to note that collaboration networks have the greatest impact among the three antecedent factors on entrepreneurship intensity. Therefore, the factors listed above have a positive effect on entrepreneurial intensity by stimulating the frequency with which entrepreneurial acts are undertaken and the degree of entrepreneurship.

Finally, the results indicate a positive relationship between entrepreneurial intensity and ambidextrous outcomes, with a coefficient of 0.274 (significant $p \leq 10\%$), confirming the thesis of Phene et al. (2012), Uotila et al. (2009), and Wang and Li (2008). For this reason, the factors that enhance entrepreneurial intensity boost ambidextrous outcomes.

However, it is necessary to take into account that the variables considered also have a positive effect on the evolution of the economy as a whole. This because these processes promote the use of new technologies and introduce innovations, which not only makes companies more competitive by finding new lines of business and domestic and international markets, but also enhances economic growth, with indirect positive effects on both welfare and job creation.

The study was undertaken for the case of countries that have a very similar structure and overlap geographically. To deepen the implications of the results and the positive effects we point out, it would be interesting to consider also the cases of countries located in other areas and with structural differences, as well as the feedback effects that could be produced.

Table 4. Matrix of correlation between latent variables.

	EI	AA	TEC	WT	AO
EI	1.000				
AA	0.269	1.000			
TEC	0.228	-0.340	1.000		
WT	0.534	0.280	0.224	1.000	
AO	0.274	0.178	0.062	0.021	1.000

Source: The Authors.

Table 5. Total and indirect effects between the latent variables.

	Total effects		Indirect effects AO
	EI	AO	
EI		0.274	
AA	0.220	0.060	0.060
TEC	0.207	0.057	0.057
WT	0.427	0.117	0.117

Source: The Authors.

Table 6. Tests of hypotheses for direct effects between latent variables.

Model	Coefficient	T Statistics	Hypothesis accepted
AA → EI	0.219*	2.015	H1
TEC → EI	0.207*	1.789	H2
WT → EI	0.426*	1.875	H3
EI → AO	0.274*	1.935	H4

Note: * = $p \leq 10\%$; ** = $p \leq 5\%$; *** = $p \leq 1\%$.

Source: The Authors.

5. Conclusions

Traditionally, the literature in this field of study has focussed mainly on analysing the relationship between ambidexterity and the entrepreneurial intensity role that entrepreneurs play, the factors that influence their decisions, and their effects on different economic variables. However, less attention has been paid to entrepreneurial intensity, defined as a combination of the frequency with which entrepreneurial acts are undertaken and the degree of entrepreneurship, and its relationship to ambidexterity, or 'the ability to simultaneously pursue both incremental and discontinuous innovation ... from hosting multiple contradictory structures, processes, and cultures within the same firm' (Tushman & O'Reilly, 1996, p. 24).

Ambidexterity is a construct that emerges through the interplay of a series of conditions disposed at multiple levels. To carry out our study, we conceptualised ambidexterity as comprising two dimensions: ambidextrous activities and ambidextrous outcomes (Laukkanen, 2012). Ambidextrous activities refer to the entrepreneur having to face competitive environments, with risk, etc., which means, among other things, having to carry out an exploration task that involves the acquisition and pursuit of knowledge (Vrontis, Thrassou, Santoro, & Papa, 2017). Such activities consist of the entrepreneur acquiring and expanding his or her knowledge to introduce the new processes and innovations that allow the business to improve. In this sense, experimenting and

transforming were carried out by considering changes in the structure of the company. Ambidextrous activities basically develop incremental and radical innovation.

Firms that want to achieve ambidexterity need to shift their structures in order to combine the firm's strategy and their structure. It is necessary to establish an autonomous exploration of subunits that were structurally separated in order to ensure the use of resources and capabilities. The description of the variants of ambidexterity shows that each is an adequate solution for solving some marketing dilemmas by implementing ambidextrous designs, since most marketing dilemmas can be reframed by adopting the exploration versus exploitation lens. The main reason that firms should become ambidextrous is related to the connection between long-term success and organisational ambidexterity.

The estimation was undertaken for the case of 25 European countries and showed the existence of a positive relationship between both ambidextrous and entrepreneurial intensity, which is similar to the other factors considered. In other words, a better education that favours entrepreneurs' competences and capabilities, among other issues, makes them react to changing circumstances in their area of operation, leading to product innovation and improvement.

The theoretical model proposed was validated through the empirical study. In this line, the four hypotheses proposed were validated, showing a positive effect between the variables considered. From the three antecedent factors considered to entrepreneurship intensity (ambidextrous activities, new technologies, and collaboration networks), collaboration networks have the greatest effect on entrepreneurship intensity with a coefficient of 0.427. This effect is greater than that obtained in H1 and H2. Furthermore, the results show that entrepreneurship intensity is related to an organisation's ability to pursue two contradictory things at the same time. Entrepreneurial intensity should have a relationship with some organisational variables, such as structure, systems, and processes that support ambidexterity.

This study has some limitations. It was conducted for countries in the same geographical area and with very similar structural levels. In future studies, it would be interesting to extend this analysis to include countries from other geographical areas for comparison. Furthermore, we intend to include more variables in the model, as well as undertake longitudinal research. Future studies should also consider more antecedent variables to ambidextrous outcomes. In this study, we analysed entrepreneurship intensity. In the same line, it would be important to study other variables that could have a positive relationship with ambidextrous activities.

Note

1. The 25 European countries are Austria, Belgium, Croatia, Denmark, Estonia, Finland, France, Germany, Greece, Hungary, Ireland, Italy, Latvia, Lithuania, the Netherlands, Norway, Poland, Portugal, Romania, Slovakia, Slovenia, Spain, Sweden, Switzerland and the United Kingdom.

Disclosure statement

No potential conflict of interest was reported by the authors.

References

- Adner, R., & Kapoor, R. (2010). Value creation in innovation ecosystems: How the structure of technological interdependence affects firm performance in new technology generations. *Strategic Management Journal*, 31(3), 306–333. doi:10.1002/smj.821
- Ahammad, M. F., Lee, S. M., Malul, M., & Shoham, A. (2015). Behavioral ambidexterity: The impact of incentive schemes on productivity, motivation, and performance of employees in commercial banks. *Human Resource Management*, 54(S1), S45–S62. doi:10.1002/hrm.21668
- Ambos, T. C., Mäkelä, K., Birkinshaw, J., & D'Este, P. (2008). When does university research get commercialized? Creating ambidexterity in research institutions. *Journal of Management Studies*, 45(8), 1424–1447. doi:10.1111/j.1467-6486.2008.00804.x
- Antonicic, B., & Hisrich, R. D. (2001). Intrapreneurship: Construct refinement and cross-cultural validation. *Journal of Business Venturing*, 16(5), 495–527. doi:10.1016/S0883-9026(99)00054-3
- Bacon, L. D. (1999). *Using LISREL and PLS to measure customer satisfaction*. Paper presented at the Seventh Annual Sawtooth Software Conference. La Jolla, CA. Retrieved from <https://pdfs.semanticscholar.org/41ae/3afc7ebec994c7cad7dcafa0deeab1f2f261.pdf>
- Barclay, D., Higgins, C., & Thompson, R. (1995). The partial least squares (PLS) approach to causal modeling. Personal computer adoption and use as an illustration. *Technology Studies, Special Issue on Research Methodology*, 2(2), 285–309.
- Brem, A. (2017). Creativity and routine: Conceptual considerations on managing organisational ambidexterity in entrepreneurial ventures. *International Journal of Entrepreneurship and Innovation Management*, 21(3), 261–273. doi:10.1504/IJEIM.2017.083472
- Burgelman, R. A. (1983). Corporate entrepreneurship and strategic management: Insights from a process study. *Management Science*, 29(12), 1349–1364. doi:10.1287/mnsc.29.12.1349
- Burgers, J. H., Jansen, J. J. P., Van Den Bosch, F. A. J., & Volberda, H. W. (2009). Structural differentiation and corporate venturing: The moderating role of formal and informal integration mechanisms. *Journal of Business Venturing*, 24(3), 206–220. doi:10.1016/j.jbusvent.2009.01.006
- Cao, Q., Gedajlovic, E., & Zhan, H. (2009). Unpacking organizational ambidexterity: Dimensions, contingencies, and synergistic effects. *Organization Science*, 20(4), 781–796. doi:10.1287/orsc.1090.0426
- Carayannis, E. G., & Campbell, D. F. (2006). *Knowledge creation, diffusion, and use in innovation networks and knowledge clusters: A comparative systems approach across the United States, Europe, and Asia*. Westport, CT: Greenwood Publishing Group.
- Cassis, Y., & Papelalis, I. (2005). Entrepreneurship in theory and history: State of the art and new perspectives. In Y. Cassis & I. Papelalis (Eds.), *Entrepreneurship in theory and history* (pp. 3–21). Basingstoke: Palgrave Macmillan.
- Castaño-Martínez, M. S., Ruiz-Fuentsanta, M. J., & Martínez-Rodríguez, I. M. (2013). The influence of socioeconomic factors on entrepreneurship and innovation. *Journal of Small Business Strategy*, 23(2), 15–28.
- Cesinger, B., Hughes, M., Mensching, H., Bouncken, R., Fredrich, V., & Kraus, S. (2016). A socioemotional wealth perspective on how collaboration intensity, trust, and international market knowledge affect family firms' multinationality. *Journal of World Business*, 51(4), 586–599. doi:10.1016/j.jwb.2016.02.004
- Cooper, A. C., & Dunkelberg, W. C. (1986). Entrepreneurship and paths to business ownership. *Strategic Management Journal*, 7(1), 53–68. doi:10.1002/smj.4250070106
- Covin, J. G., & Slevin, D. P. (1989). Strategic management of small firms in hostile and benign environments. *Strategic Management Journal*, 10(1), 75–87. doi:10.1002/smj.4250100107
- Dai, Y., Du, K., Byun, G., & Zhu, X. (2017). Ambidexterity in new ventures: The impact of new product development alliances and transactive memory systems. *Journal of Business Research*, 75, 77–85.

- Dakhli, M., & De Clercq, D. (2004). Human capital, social capital and regional innovation: A multi-country study. *Entrepreneurship and Regional Development*, 16(2), 107–128. doi: [10.1080/08985620410001677835](https://doi.org/10.1080/08985620410001677835)
- Davis, J. P., & Eisenhardt, K. M. (2011). Rotating leadership and collaborative innovation: Recombination processes in symbiotic relationships. *Administrative Science Quarterly*, 56(2), 159–201. doi:[10.1177/0001839211428131](https://doi.org/10.1177/0001839211428131)
- De Carolis, D. M., & Saporito, P. (2006). Social capital, cognition, and entrepreneurial opportunities: A theoretical framework. *Entrepreneurship Theory and Practice*, 30(1), 41–56. doi: [10.1111/j.1540-6520.2006.00109.x](https://doi.org/10.1111/j.1540-6520.2006.00109.x)
- Drucker, P. F. (1954). *The practice of management*. London: William Heinemann.
- Falk, R., & Miller, N. (1992). *A primer for soft modeling*. Akron, OH: University of Akron Press.
- Fornell, C. (1982). A second generation of multivariate analysis: An overview. In C. Fornell (Ed.), *A second generation of multivariate analysis* (pp. 1–21). New York, NY: Praeger Publishers.
- Fornell, C., & Larcker, D. (1981). Evaluating structural equations models with unobservable variables and measurement error. *Journal of Marketing Research*, 18(1), 39–50. doi:[10.2307/3151312](https://doi.org/10.2307/3151312)
- Frohman, A. L. (1983). Technology as a competitive weapon. *Harvard Business Review*, 60(1), 97–104.
- Fukuyama, F. (2000). *Social capital and civil society* (International Monetary Fund Working Paper, 74). Washington, DC: Springer.
- Galindo, M. A., & Méndez, M. T. (2014). Entrepreneurship, economic growth, and innovation: Are feedback effects at work? *Journal of Business Research*, 67 (5), 825–829. doi:[10.1016/j.jbusres.2013.11.052](https://doi.org/10.1016/j.jbusres.2013.11.052)
- Gartner, W. B. (1985). A conceptual framework for describing the phenomenon of new venture creation. *Academy of Management Review*, 10(4), 696–706. doi:[10.5465/amr.1985.4279094](https://doi.org/10.5465/amr.1985.4279094)
- Gibson, C. A. B., & Birkinshaw, J. (2004). The antecedents, consequences, and mediating role of organizational ambidexterity. *Academy of Management Journal*, 47(2), 209–226. doi: [10.2307/20159573](https://doi.org/10.2307/20159573)
- Ginsberg, A. (1985). Measuring changes in entrepreneurial orientation following industry deregulation: The development of a diagnostic instrument. In G. B. Roberts (Ed.), *Proceedings: Discovering entrepreneurship* (pp. 50–57). Marietta, GA: U.S. International Council for Small Business.
- Global Entrepreneurship Monitor Project (GEM) (2016). APS-Global data 2012. Retrieved from <http://www.gemconsortium.org/data/sets>. Accessed 25 May 2016.
- Gulati, R., & Sytch, M. (2007). Dependence asymmetry and joint dependence in interorganizational relationships: Effects of embeddedness on a manufacturer's performance in procurement relationships. *Administrative Science Quarterly*, 52(1), 32–69. doi:[10.2189/asqu.52.1.32](https://doi.org/10.2189/asqu.52.1.32)
- Hair, J. F., Hult, G. T. M., Ringle, C., & Sarstedt, M. (2016). *A primer on partial least squares structural equation modeling (PLS-SEM)*. Thousand Oaks, CA: Sage Publications.
- Heavy, C., & Simsek, Z. (2017). Distributed cognition in top management teams and organizational ambidexterity: The influence of transactive memory systems. *Journal of Management*, 43(3), 919–945. doi:[10.1177/0149206314545652](https://doi.org/10.1177/0149206314545652)
- Hitt, M. A., Lee, H., & Yucl, E. (2002). The importance of social capital to the management of multinational enterprises: Relational networks among Asian and Western Firms. *Asia Pacific Journal of Management*, 19(2/3), 353–372.
- Johanson, J., & Vahlne, J. E. (2009). The Uppsala internationalization process model revisited: Form liability of foreignness to liability of outsidership. *Journal of International Business Studies*, 40(9), 1–21.
- Johnson, M. W., Christensen, C. M., & Kagermann, H. (2008). Reinventing your business model. *Harvard Business Review*, 86(12), 50–57.

- Jones, G. R., & Butler, J. E. (1992). Managing internal corporate entrepreneurship: An agency theory perspective. *Journal of Management*, 18(4), 733–749. doi:10.1177/014920639201800408
- Kaasa, A. (2009). Effects of different dimensions of social capital on innovative activity: Evidence from Europe at the regional level. *Technovation*, 29(3), 218–233. doi:10.1016/j.technovation.2008.01.003
- Kafouros, M. I., Buckley, P. J., Sharp, J. A., & Wang, C. (2008). The role of internationalization in explaining innovation performance. *Technovation*, 28(1-2), 63–74.
- Koryak, O., Lockett, A., Hayton, J., Nicolaou, N., & Mole, K. (2018). Disentangling the antecedents of ambidexterity: Exploration and exploitation. *Research Policy*, 47(2), 413–427.
- Kotabe, M., Srinivasan, S. S., & Aulakh, P. S. (2002). Multinationality and firm performance: The moderating role of R&D and marketing capabilities. *Journal of International Business Studies*, 33(1), 79–97.
- Krauss, S. I., Frese, M., Friedrich, C., & Unger, J. M. (2005). Entrepreneurial orientation: A psychological model of success among southern African small business owners. *European Journal of Work and Organizational Psychology*, 14(3), 315–344. doi:10.1080/13594320500170227
- Kuratko, D. F., & Morris, M. H. (2018). Corporate entrepreneurship: A critical challenge for educators and researchers. *Entrepreneurship Education and Pedagogy*, 1(1), 42–60. doi:10.1177/2515127417737291
- Kyoon, D. (2014). Substructures of perceived knowledge quality and interactions with knowledge sharing and innovativeness: A sense making perspective. *Journal of Knowledge Management*, 18(3), 523–537.
- Laukkanen, S. (2012). *Making sense of ambidexterity. A process view of the renewing effects of innovation activities in a multinational enterprise*. Helsinki: Hanken School of Economics.
- Lawson, B., & Samson, D. (2001). Developing innovation capability in organisations: A dynamic capabilities approach. *International Journal of Innovation Management*, 05(03), 377–400. doi:10.1142/S1363919601000427
- Liao, J., & Welsch, H. (2003). Social capital and entrepreneurial growth aspiration: A comparison of technology- and non-technology-based nascent entrepreneurs. *Journal of High Technology Management Research*, 14(1), 149–170. doi:10.1016/S1047-8310(03)00009-9
- Lumpkin, G. T., & Dess, G. G. (1996). Clarifying the entrepreneurial orientation construct and linking it to performance. *Academy of Management Review*, 21(1), 135–172. doi:10.2307/258632
- Lyon, D. W., Lumpkin, G. T., & Dess, G. G. (2000). Enhancing entrepreneurial orientation research: Operationalizing and measuring a key strategic decision making process. *Journal of Management*, 26(5), 1055–1085. doi:10.1177/014920630002600503
- March, J. G. (1991). Exploration and exploitation in organizational learning. *Organization Science*, 2(1), 71–87. doi:10.1287/orsc.2.1.71
- Martínez-Conesa, I., Soto-Acosta, P., & Carayannis, E. G. (2017). On the path towards open innovation: Assessing the role of knowledge management capability and environmental dynamism in SMEs. *Journal of Knowledge Management*, 21(3), 553–570. doi:10.1108/JKM-09-2016-0403
- Mathews, J. (2017). Entrepreneurial leadership: A conceptual examination. *IUP Journal of Entrepreneurship Development*, 14(4), 31–50.
- Meglio, O., King, D. R., & Risberg, A. (2015). Improving acquisition outcomes with contextual ambidexterity. *Human Resource Management*, 54 (S1), S29–S43. doi:10.1002/hrm.21721
- Miles, M. P., & Arnold, D. R. (1991). The relationship between marketing orientation and entrepreneurial orientation. *Entrepreneurship Theory and Practice*, 15(4), 49–65. doi:10.1177/104225879101500407
- Miller, D. (1983). The correlates of entrepreneurship in three types of firms. *Management Science*, 29(7), 770–791. doi:10.1287/mnsc.29.7.770
- Morris, M. H., & Kuratko, D. F. (2002). *Corporate entrepreneurship—entrepreneurial development within organizations*. Fort Worth, TX: Harcourt, Inc.

- Morris, M. H., & Paul, G. W. (1987). The relationship between entrepreneurship and marketing in established firms. *Journal of Business Venturing*, 2(3), 247–259. doi:10.1016/0883-9026(87)90012-7
- Morris, M. H., & Sexton, D. L. (1996). The concept of entrepreneurial intensity: Implications for company performance. *Journal of Business Research*, 36(1), 5–13. doi:10.1016/0148-2963(95)00158-1
- Nahapiet, J., & Ghoshal, S. (1998). Social capital, intellectual capital, and the organizational advantage. *Academy of Management Review*, 23(2), 242–266. doi:10.5465/amr.1998.533225
- Nunnally, J., & Bernstein, I. (1994). *Psychometric theory*. New York, NY: McGraw Hill.
- Onyema, G. (2016). Towards building internal social network architecture that drives innovation: A social exchange theory perspective. *Journal of Knowledge Management*, 20(3), 534–556.
- O'Reilly, C. A., & Tushman, M. L. (2013). Organizational ambidexterity: Past, present and future. *Academy of Management Perspectives*, 27(4), 324–338. doi:10.5465/amp.2013.0025
- Palacios-Marqués, D., Popa, S., & Alguacil-Mari, M. P. (2016). The effect of online social networks and competency-based management on innovation capability. *Journal of Knowledge Management*, 20(3), 499–511. doi:10.1108/JKM-05-2015-0175
- Patel, P. C., Messersmith, J. G., & Lepak, D. P. (2013). Walking the tight-rope: An assessment of the relationship between high performance work systems and organizational ambidexterity. *Academy of Management Journal*, 56(5), 1420–1442. doi:10.5465/amj.2011.0255
- Phelan, S., Dalgic, T., Li, D., & Sethi, D. (2006). The development of entrepreneurial networks: A necessary condition for international new ventures. *Strategic Management Review*, 1(1), 1–21.
- Phene, A., Tallman, S., & Almeida, P. (2012). When do acquisitions facilitate technological exploration and exploitation? *Journal of Management*, 38(3), 753–783.
- Pinchot, G. (1985). *Intrapreneuring*. New York, NY: Harper & Row.
- Pittiglio, R., Sica, E., & Villa, S. (2009). Innovation and internationalization: the case of Italy. *The Journal of Technology Transfer*, 34(6), 588–602. doi:10.1007/s10961-009-9107-5
- Rezende, J., Torres, A., Correia, A., Nicolini, A., & Bernardes, R. (2016). Integrating enabling contexts and ambidexterity to create intellectual capital faculty's competencies on undergraduate business management programs. *Intangible Capital*, 12(4), 1006–1039. Retrieved from <http://www.intangiblecapital.org/index.php/ic/article/view/724/569> doi:10.3926/ic.724
- Roldán-Bravo, M. I., Ruiz-Moreno, A., & Lloréns-Montes, F. J. (2018). Examining desorptive capacity in supply chains: The role of organizational ambidexterity. *International Journal of Operations & Production Management*, 38(2), 534–553. doi:10.1108/IJOPM-12-2016-0751
- Rothaermel, F. T., & Alexandre, M. T. (2009). Ambidexterity in technology sourcing: The moderating role of absorptive capacity. *Organization Science*, 20(4), 759–780. doi:10.1287/orsc.1080.0404
- Rothaermel, F. T., & Hess, A. M. (2007). Building dynamic capabilities: Innovation driven by individual, firm, and network-level effects. *Organization Science*, 18(6), 898–921. doi:10.1287/orsc.1070.0291
- Sarkees, M., & Hulland, J. (2009). Innovation and efficiency: It is possible to have it all. *Business Horizons*, 52(1), 45–55. doi:10.1016/j.bushor.2008.08.002
- Scheepers, R., Hough, J., & Bloom, J. (2013). Entrepreneurial intensity: A comparative analysis of established companies in South Africa. *South African Journal of Economic and Management Sciences*, 10(2), 238–255. doi:10.4102/sajems.v10i2.585
- Schollhammer, H. (1982). Internal corporate entrepreneurship. In C. A. Kent., D. L. Sexton, & K. H. Vesper (Eds.). *Encyclopedia of entrepreneurship* (pp. 209–229). Englewood Cliffs, NJ: Prentice Hall.
- Schumpeter, J. A. (1934). *The theory of economic development*. Cambridge, MA: Harvard University Press.
- Simsek, Z., Heavey, C., Veiga, J. F., & Souder, D. (2009). A typology for aligning organizational ambidexterity's conceptualizations, antecedents, and outcomes. *Journal of Management Studies*, 46(5), 864–894. doi:10.1111/j.1467-6486.2009.00841.x

- Soto-Acosta, P., & Meroño-Cerdan, A. L. (2008). Analyzing e-business value creation from a resource-based perspective. *International Journal of Information Management*, 28(1), 49–60. doi:10.1016/j.ijinfomgt.2007.05.001
- Stevenson, H. H., & Jarillo, J. C. (1990). A paradigm of entrepreneurship: Entrepreneurial management. *Strategic Management Journal*, 11(5), 17–27.
- Subramaniam, M., & Youndt, M. A. (2005). The influence of intellectual capital on the types of innovative capabilities. *Academy of Management Journal*, 48(3), 450–463. doi:10.5465/amj.2005.17407911
- Swedberg, R. (2000). *Max Weber and the idea of economic sociology*. New Jersey, USA: Princeton University Press.
- Tenenhaus, M. (1998). *La régression PLS: Théorie et pratique*. Paris: Technip.
- Tsai, W., & Ghoshal, S. (1998). Social capital and value creation: The role of intrafirm networks. *Academy of Management Journal*, 41(4), 464–478. doi:10.2307/257085
- Tushman, M. L., & O'Reilly, C. A. (1996). The ambidextrous organization: Managing evolutionary and revolutionary change. *California Management Review*, 38(4), 8–23. doi:10.2307/41165852
- Tushman, M., Smith, W. K., Wood, R. C., Westerman, G., & O'Reilly, C. (2010). Organizational designs and innovation streams. *Industrial and Corporate Change*, 19(5), 1331–1366. doi:10.1093/icc/dtq040
- Uotila, J., Maula, M., Keil, T., & Zahra, S. A. (2009). Exploration, exploitation, and financial performance: Analysis of S&P 500 corporations. *Strategic Management Journal*, 30(2), 221–231.
- Vesper, K. H. (1984). Three faces of corporate entrepreneurship: A pilot study. In J. A. Homaday, F. Tarpley, Jr., J. A. Timmons, & K. H. Vesper (Eds.), *Frontiers of entrepreneurship research* (pp. 294–326). Wellesley, MA: Babson College.
- Vrontis, D., Thrassou, A., Santoro, G., & Papa, A. (2017). Ambidexterity, external knowledge and performance in knowledge-intensive firms. *The Journal of Technology Transfer*, 42(2), 374–388. doi:10.1007/s10961-016-9502-7
- Wang, H., & Li, J. (2008). Untangling the effects of overexploration and overexploitation on organizational performance: The moderating role of environmental dynamism. *Journal of Management*, 34(5), 925–951.
- Williams, A. M., & Shaw, G. (2011). Internationalization and innovation in tourism. *Annals of Tourism Research*, 38(1), 27–51. doi:10.1016/j.annals.2010.09.006
- Wong, K. K. K. (2013). Partial least squares structural equation modeling (PLS-SEM) techniques using SmartPLS. *Marketing Bulletin*, 24(1), 1–32.
- World Bank (2016). World Development Indicators. Retrieved from <http://data.worldbank.org/data-catalog/world-development-indicators>. Accessed 2 April 2016.
- Zahra, S. A. (1993). A conceptual model of entrepreneurship as firm behavior: A critique and extension. *Entrepreneurship Theory and Practice*, 17(4), 5–21. doi:10.1177/104225879301700401
- Zahra, S. A., & Covin, J. G. (1995). Contextual influences on the corporate entrepreneurship-performance relationship: A longitudinal analysis. *Journal of Business Venturing*, 10(1), 43–58. doi:10.1016/0883-9026(94)00004-E
- Zahra, S. A., & Nielsen, A. P. (2002). Sources of capabilities, integration and technology commercialization. *Strategic Management Journal*, 23(5), 377–398. doi:10.1002/smj.229
- Zortea-Johnston, E., Darroch, J., & Matear, S. (2012). Business orientations and innovation in small and medium sized enterprises. *International Entrepreneurship and Management Journal*, 8(2), 145–164. doi:10.1007/s11365-011-0170-7

© 2019 The Author(s). Published by Informa UK Limited, trading as Taylor and Francis Group. This work is licensed under the Creative Commons Attribution License creativecommons.org/licenses/by/4.0/ (the “License”). Notwithstanding the ProQuest Terms and Conditions, you may use this content in accordance with the terms of the License.